

MC

241

Box

2 Folder

28

Heat to Electricity by Thermionic Emission, 1959

PHILIPS RESEARCH LABORATORIES
N.V. PHILIPS' GLOEILAMPENFABRIEKEN
EINDHOVEN NETHERLANDS

TELEPHONE
EINDHOVEN (K 4900) 6000

CABLE ADDRESS
PHILAB EINDHOVEN

Prof. C/Kr

May 12, 1959.

Prof. Wayne B. Nottingham,
Massachusetts Institute of Technology
Department of Physics
Room 6-205,
Cambridge 39, Mass.

Dear Dr. Nottingham,

The time you suggest suits our people well
and we are looking forward to your visit.

With kind regards,

Yours sincerely,

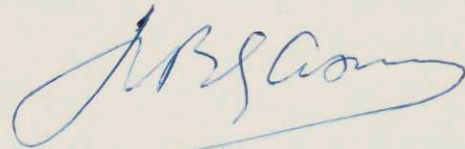

Prof. Dr. H.B.G. Casimir.

Comments On
"Heat to Electricity by Thermionic Emission"

Wayne B. Nottingham
Research Laboratory of Electronics
Massachusetts Institute of Technology
Cambridge, Massachusetts

In a recent issue, V. C. Wilson⁽¹⁾ has made available some interesting data concerning his investigations of the thermionic emission diode as a heat-to-electrical-power transducer. He describes measurements made on a diode containing a molybdenum filament heated to a temperature of 1900°K in the presence of cesium vapor maintained at a condensation temperature of 546°K .^{56x} The interpretation which he offers concerning this experiment is open to question.

This criticism applies to the concept that significant information can be obtained from the "open circuit voltage." Wilson attempts to deduce the value of the work-function of the collector by the fact that the measured open circuit voltage with a "low cesium pressure and high cathode temperature" provides a means for evaluating the collector work-function. His interpretation of "open circuit voltage" is that it corresponds to a condition which he describes by: ". then the cathode and anode surfaces should be at about the same potential." Such a conclusion is not warranted. The condition at the surface of the collector that is associated with the open circuit voltage is that the net collector current is zero. At this particular potential difference between the Fermi level of the emitter and the Fermi level of the collector, electrons will go from the emitter to the collector. The opposite direction of current flow will be related to the reception at the collector surface of positive ions and in addition to this there will be the thermionically emitted electrons from the collector surface. If there are no external leakage currents, the open circuit voltage will be determined by this balance of incoming and outgoing charges and bears no relation to the equality of the surface potentials.

Under the low pressure condition we assume that the cesium condensation temperature was at least 300°K and the collector temperature close to 800°K . The open circuit potential of 3.05 v combined with the fact that the emitter was

This work has been supported in part by the U. S. Army (Signal Corps), the U. S. Air Force (Office of Scientific Research, Air Research and Development Command), and the U. S. Navy (Office of Naval Research).

¹ V. C. Wilson, J. Appl. Phys. 30, 475 (1959).

at 1900°K demands that the collector work-function be not less than 1.8 ev. A detailed analysis of the current-voltage relation which Wilson could have observed but did not report would have permitted him to determine the true work-function of his collector.

Additional evidence concerning the meaning of the open circuit voltage comes from Wilson's experiment since as a result of increasing the cesium concentration by raising its condensation temperature to 564°K, the open circuit voltage dropped to 2.75 volts. The only conclusion that one can draw from this fact is that an increase in the electron emission current of 6.2 was needed to offset the increased emission from the collector (including increased ion arrival) if one assumes no change in the collector work-function. An increase in concentration could increase the true work-function of the collector or decrease it depending on the temperature of the collector.

A detailed study of the results published by Taylor and Langmuir⁽²⁾ shows that a critical relation exists between the maximum cesium condensation temperature and the tungsten surface temperature for complete cesium ionization at the surface. This relation is

$$\max T_{Cs} = \frac{T_W}{3.6} \quad (1)$$

In this equation the maximum cesium temperature is $\max T_{Cs}$ and the corresponding tungsten temperature is T_W . If for a given cesium temperature, the tungsten temperature is allowed to fall, the ion production will drop very suddenly a factor of 10 or more when the cesium temperature is higher than that given by Eq. 1. For molybdenum the factor is probably equal to or greater than 3.6 and therefore with a 1900°K molybdenum filament and a condensation temperature of 564°K, the ion yield will be much less than 10 per cent of the arrival rate of neutral cesium atoms.

In order to understand one of the experiments of Wilson, we first summarize the experimental facts. 1. The single filament was molybdenum operated at 1900°K. 2. The collector was a cesiated silver surface of relatively low but unknown work-function. 3. The open circuit voltage with $T_{Cs} = 564^\circ\text{K}$ was 2.75 v. 4. Under conditions that probably corresponded to maximum power output, the current density of the emitter was 4 amps/cm². 5. The voltage difference between the Fermi level in the emitter and that in the

² J. B. Taylor and I. Langmuir, Phys. Rev. 44, 423 (1933).

collector was 0.78 v which represented the output voltage. 6. The arrival rate of neutral atoms at the surface of the heated filament was 3.5×10^{20} atoms per second for each square centimeter ($T_{Cs} = 564^{\circ}\text{K}$).

In Fig. 1 the emitter work-function ϕ_1 is shown as being 2.5. This is arbitrarily taken since there is no information in the available facts that permits a determination of this value except to state that it is less than 3 ev. The arrival rate of atoms can be 7000 times greater than the effective production rate of ions. This permits the drawing of the ion space-charge barrier shown at B_+ at 2.25 ev from the Fermi level. With the surface potential at the collector 4.55 volts negative the electron current to the collector will be 2.5×10^{-4} amp/cm² as calculated at the emitter surface. With the atom arrival rate mentioned ions that are generated at the heated surface will pass over the barrier at B_+ in sufficient number to balance the arrival rate of electrons. Note that in this space there is a positive ion space charge.

As the Fermi level of the collector is made less negative than the 2.75 shown in Fig. 1, the electron current to the collector increases exponentially and the motive pattern changes to that of Fig. 2 as described in the experiment. The new diagram implies that over the range of applied voltage from 2.75 to about 1.5 volts, the electron current received at the collector should increase approximately 2000 fold while the ion current would decrease only slightly. At still smaller voltage the current increases less rapidly and the power reaches a maximum. The difference in potential between the space-charge minimum at B_- and the surface of the collector should not be attributed to a "drag" on the electrons due to the neutral atoms present since the fractional energy loss suffered by an electron upon collision with a neutral atom will not be more than 2×10^{-5} .

The interpretation placed on Wilson's experiment in this letter is very different from his and its validity can be tested by experiment. It is hoped that Dr. Wilson will be able to supply the additional experimental information.

Supplement to Preliminary Report on

ELECTRON TEMPERATURES OF THERMIONIC CATHODES

A report on the electron energy distribution and its measurement as a mean of evaluating thermionic cathode temperatures was prepared and dated January 8, 1959. On page 11 of that report the importance of equipment layout was emphasized. A supplementary statement on this subject has been requested.

Since the detector needed to measure the very small currents involved in an energy distribution study used consists of a dc amplifier containing such nonlinear components as vacuum tubes and transistors. In general ac pickup put into these nonlinear elements result in a dc output which interferes with the accuracy of measurement. All such interference must be carefully avoided.

In some laboratories energy distribution measurements have been made without the control of the electron trajectories that can be accomplished by having a suitably strong magnetic field present. In practical tubes, it is very rarely possible to obtain accurate results without the use of a magnetic field. The reason for this difficulty is that a considerably^e variation in applied potentials must be used in order to determine the electron energy distribution. If this variation in applied potential results in an alteration in the electron trajectories, then faulty results will be obtained. If one first establishes a true temperature by studying a given tube type with a magnetic field and then determines the correction necessary to correspond to observations in that particular tube type without a magnetic field, routine measurements may be made.

In many commercial instruments the measurement of a current is accomplished by having the current flow through a high resistance which

in turn results in a deviation of the potential of the electron collecting element unless the loop gain of the feedback circuit is sufficiently high to make this deviation negligible. It is therefore very important that the observer has a clear understanding of the properties of his detecting instrument so that corrections can be made to offset this difficulty. In some cases, the correction cannot be made with suitable accuracy and results of observations with that instrumentation are ~~likely to~~ likely to be faulty.

Comments On
Heat to Electricity by Thermionic Emission

In a recent issue, V. C. Wilson⁽¹⁾ has made available some interesting data concerning his investigations of the thermionic emission diode as a heat-to-electrical-power transducer. Specifically he describes some measurements made on a diode containing a molybdenum filament heated to a temperature of 1900°K in the presence of cesium vapor maintained at a condensation temperature of 564°K . The interpretation which he offers concerning this experiment is open to question. Specifically this implied criticism applies to the concept that significant information can be obtained from the "open circuit voltage". Wilson attempts to deduce the value of the work-function of the collector by the fact that the measured open circuit voltage with a "low cesium pressure and high cathode temperature" provides a means for evaluating the collector work-function. He indicates that his interpretation of "open circuit voltage" gives ~~the~~ a condition which he describes in the words: ". . . . then the cathode and anode surfaces should be at about the same potential." Such a conclusion is clearly not warranted. The condition at the surface of the collector that is associated with the open circuit voltage is that the net current to the collector is zero. . . . At this particular potential difference between the Fermi level of the emitter and the Fermi level of the collector, electrons will go from the emitter to the collector. The opposite direction of current flow will be related to the reception at the collector surface of positive ions. In addition to this there will be the thermionically emitted electrons from the collector surface, if it has a very low work-function and the photoelectrically emitted electrons. If there are no external leakage currents, then the floating potential, or the open circuit voltage, will be determined by this balance of incoming and outgoing charges.

and bears no relation to the equality of the surface potentials as indicated by Wilson.

In order to deduce his value of the true work-function of the collector to be 1.15 ev, he assumes that a published value of the Richardson work-function for molybdenum of 4.2 ev has significance in this experiment. It is true that a value of the Richardson work-function was reported by L. A. DuBridge and W. W. Roehr⁽²⁾ which was 4.15. The fact that the Richardson work-function obtained in this manner does not represent the true work-function is well established by the studies of Hutson⁽³⁾ and others in relation to the true work-function evaluation of tungsten. The range of work-function for tungsten is at least from 4.4 to 5.3 depending on the particular crystallographic plane that is exposed. The Richardson work-function is purely an empirical number which will fit into a Richardson equation and yield a fairly good representation of the average emission yield as a function of temperature. An extended discussion of these facts is covered in "Thermionic Emission"⁽⁴⁾.

A detailed analysis of the current-voltage relation which Wilson could have observed but did not report would have permitted him to determine the true work-function of his collector. In all probability it was greater than 1.15. Additional evidence concerning the meaning of the open circuit voltage comes from Wilson's experiment in that as a result of increasing the cesium concentration by raising its condensation temperature to 564°K, the open circuit voltage dropped to 2.75. The only conclusion that one can draw from this fact is that an increase in the electron emission current of 6.2 was needed to offset the increase in ion yield to the collector if one assumes that the change in the collector work-function was small in spite of the change in cesium concentration. Actually an increase in concentration could increase the true work-function of the collector or it could decrease it depending on the temperature of the collector. In order to

derive the maximum benefit from the experimental detail given by Wilson, he should have stated the cesium condensation temperature associated with a "low cesium pressure". A detailed study of the results published by Taylor and Langmuir⁽⁵⁾ shows that a critical relation exists in the case of a tungsten surface for the maximum cesium condensation temperature in its relation to the tungsten surface temperature for complete cesium ionization at the surface. This relation is

(1)

In this equation the maximum cesium temperature is T_{Cs}^{\max} and the corresponding tungsten temperature is T_W . If for a given cesium temperature, the tungsten temperature is allowed to fall, the ion production will drop very suddenly a factor of 10 or more when the cesium temperature is higher than that given by Eq. 1. For molybdenum the factor is probably equal to or greater than 3.6 and therefore with a 1900°K molybdenum filament and a condensation temperature of 564°K , the ion yield will be \approx much less than 10 per cent of the arrival rate of neutral cesium atoms. We might conclude very indirectly from the evidence here that a "low ^{cesium} pressure" corresponds to a condensation temperature of 440°K or less.

In order to understand one of the experiments of Wilson, we first summarize the experimental facts. 1. The emission and ionization filament was molybdenum operated at 1900°K . 2. The collector was a cesiated silver surface of relatively low but unknown work-function. 3. The open circuit voltage which represents the balance between electron and ion arrival was 2.75 v. 4. Under conditions that probably corresponded to maximum power output, the current density of the emitter was $4\text{amps}/\text{cm}^2$.⁵ The voltage difference between the Fermi level

in the emitter and that in the collector was 0.78 v which represented the output voltage. 6. The arrival rate of neutral atoms at the surface of the heated filament was 3.5×10^{20} atoms per second for each square centimeter.

If the filament had been tungsten the production rate of ions would have been given by the following equation:

(2)

Here μ_t is the ion production rate in ions per second for each square centimeter, and μ_a is the atom arrival rate. Under the conditions of the experiment, the ion current produced was probably less than 2.9×10^{-2} amp/cm². If all of these ions are accelerated to the collector, then an equal number of electrons will arrive at the collector if its surface potential is 3.8 v negative with respect to the Fermi level of the emitter. Since the ion current may be as much as a factor of 10 lower than 2.9×10^{-2} amp/cm², it could be nearly four tenths of a volt more negative, making it 4.2. On this basis the work-function of the collector is bracketed between 1.05 and 1.45 v. Clearly a direct determination of this true work-function would have been better than this guess. Figure 1 has been prepared to represent the motive function in the space between the emitter and the collector under the condition described here of a 2.75 open circuit voltage.

In Fig. 1 the emitter work-function ϕ_1 is shown as being 2.5. This is arbitrarily taken since there is no information in the available facts ^{that} ~~is~~ permits a determination of this value except to state that it is less than 3 ev. The arrival rate of atoms can be 2000 times greater than the effective production rate of ions. ~~This~~ permits the drawing of the ion space-charge barrier shown at B_+ at 2.65 ev from the Fermi level. With this surface potential at the collector 4 volts negative the electron current to the collector will be 5.7×10^{-3} amp/cm² (at the emitter):

With the atom arrival rate mentioned ions that are generated at the heated surface will pass over the barrier at B_+ in sufficient number to balance the arrival rate of electrons. Note that in this space there is a positive ion space charge.

As the Fermi level of the collector is made less negative than the 2.75 shown in Fig. 1, the electron current to the collector increases exponentially and the motive pattern changes to that of Fig. 2 under the condition described in the experiment. New diagrams imply that over the range of applied voltage from 2.75 to about 2 volts, the electron current received at the collector should increase approximately 100 ~~volts~~ fold while the ion current would decrease only slightly. At still less negative voltages such as 0.78 all of the ions produced at the emitter will return to it. The difference in potential between the space-charge minimum at B_- and the surface of the collector should not be attributed to a drag on the electrons due to the neutral atoms present since the ^{fractional} energy loss suffered by an electron upon collision with a neutral atom will not be more than 2×10^{-5} .

Clearly the interpretation placed on Wilson's experiment in this letter is very different from his and its validity can easily be tested by experiment. It is hoped that Dr. Wilson will be able to supply the additional experimental information.

CESIUM PLASMA DIODE AS A HEAT-TO-ELECTRICAL-POWER TRANSDUCER.
Wayne B. Nottingham, Massachusetts Institute of Technology, Cambridge, Mass.

The new interest in the direct conversion of heat-to-electrical power has stimulated research in both the application of the high vacuum diode and the plasma diode to accomplish this purpose. The theory of the high vacuum diode is relatively simple and the experimental verification of the theory has been satisfactory. The plasma diode which depends on the ionization at the hot surface cannot be worked out in all of its detail at present because of the lack of certain fundamental experimental data. It is possible to make use of published results of Taylor and Langmuir and a detailed analysis of recent thermionic studies. To carry the understanding of the plasma diode far enough along to make a direct comparison with experiment. This analysis involves a better understanding of the phenomenon of surface ionization and a treatment of the influence of ions, that is, their generation and their delivery to neutralize electron space charge. When applied to the experimental data available, an interesting result comes as an important simplification. Essential to the theory of the high vacuum diode is the knowledge of the emitter temperature and the diode spacing. The electrical characteristics of the plasma diode have been found to be very closely duplicated by the theory of the high vacuum diode with the exception that the characteristic effective distance is greatly reduced from the actual physical separation between the planes of the diode and because of this fact combined with space-charge theory the efficiency is tremendously improved.

This work has been supported in part by the U. S. Army (Signal Corps), the U. S. Air Force (Office of Scientific Research, Air Research and Development Command), and the U. S. Navy (Office of Naval Research).

Also the Thermo-Electron Engineering Corporation has contributed toward the support of this research and supplied significant experimental data.

NOTE: GAIN OF AMPLIFIER IS APPROXIMATELY 5000. BREAKING CONNECTION AT X-X AND INSERTING 2N217 EMITTER FOLLOWER, SHOWN BY DOTTED CONNECTIONS, WILL INCREASE THIS 4-5 TIMES. C-2 MUST BE INCREASED ALSO.

R-12 - 600Ω plus 500-Ω ADJUSTABLE. SET 50 METER HEADS 150 Volts FULL SCALE IN X10 POSITION. +26 Volts

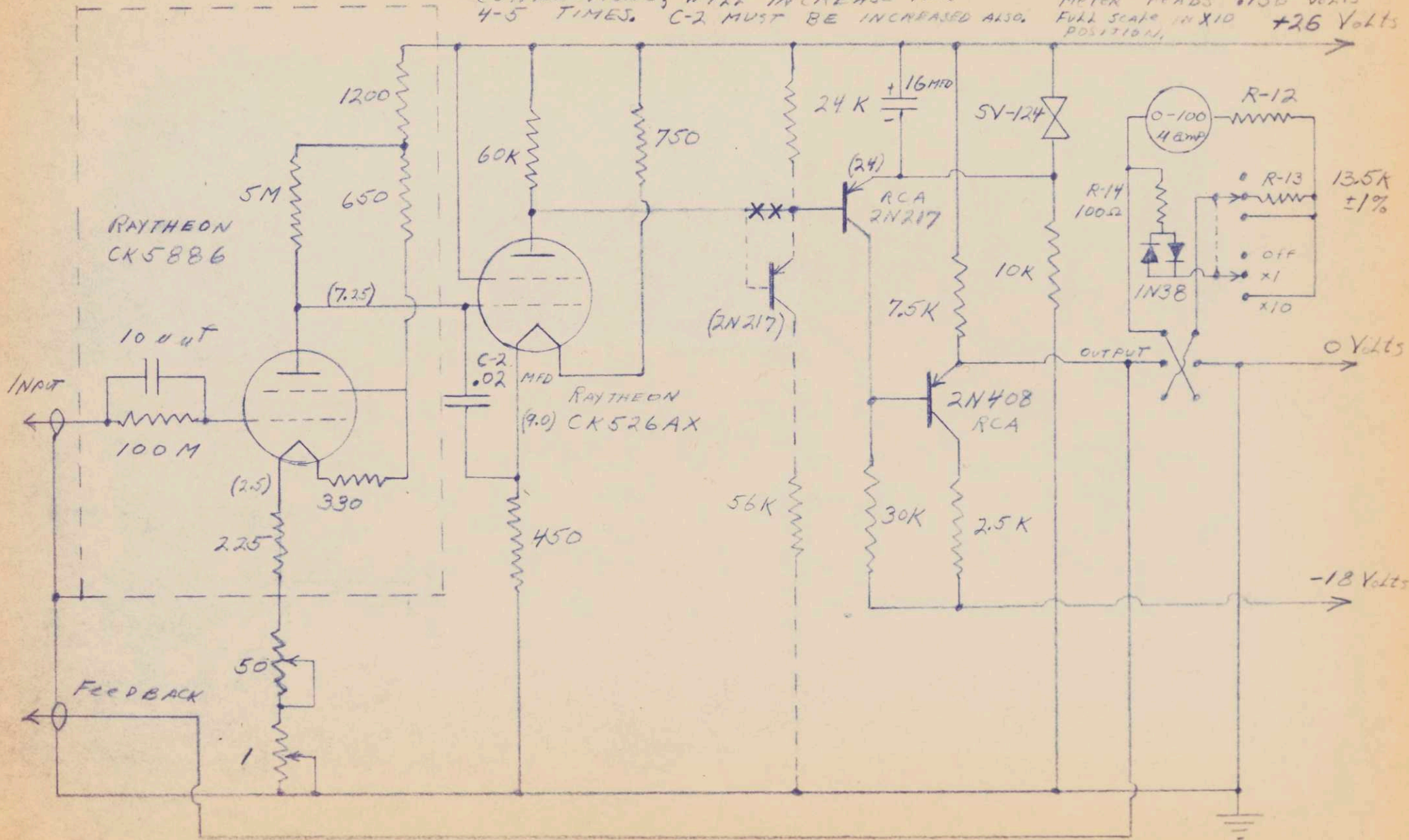

ELECTROMETER AMPLIFIER
REVISED 4 1 JUNE 1959

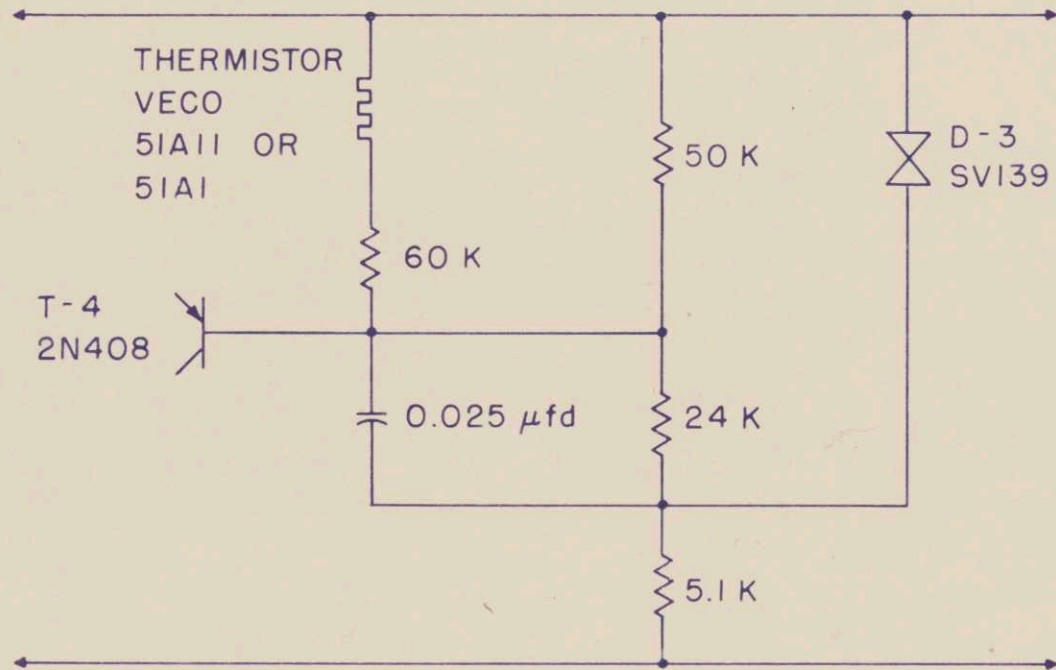

9/12/57

31

ELECTROMETER
OLD POWER SUPPLY

EXCELLENT REGULATION
BUT DRIFTS WITH TEMP.

MASSACHUSETTS INSTITUTE OF TECHNOLOG

..... 19

Memo to..... Room..... Ext.....

from..... Room..... Ext.....

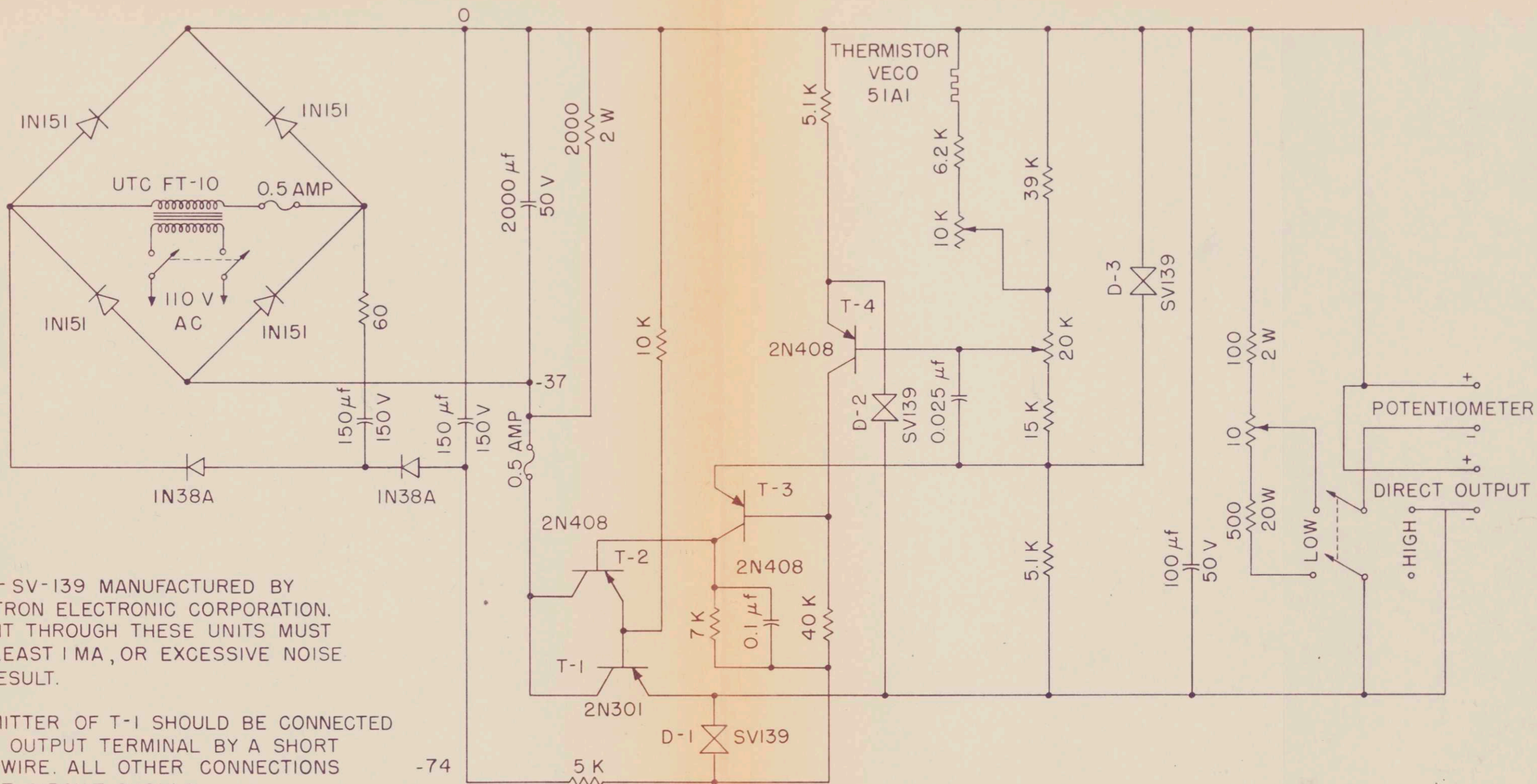

NOTES:

1. D-1,2,3-SV-139 MANUFACTURED BY TRANSITRON ELECTRONIC CORPORATION. CURRENT THROUGH THESE UNITS MUST BE AT LEAST 1 MA, OR EXCESSIVE NOISE WILL RESULT.
2. THE EMITTER OF T-1 SHOULD BE CONNECTED TO THE OUTPUT TERMINAL BY A SHORT HEAVY WIRE. ALL OTHER CONNECTIONS TO THAT CIRCUIT SHOULD BE MADE THERE.

264

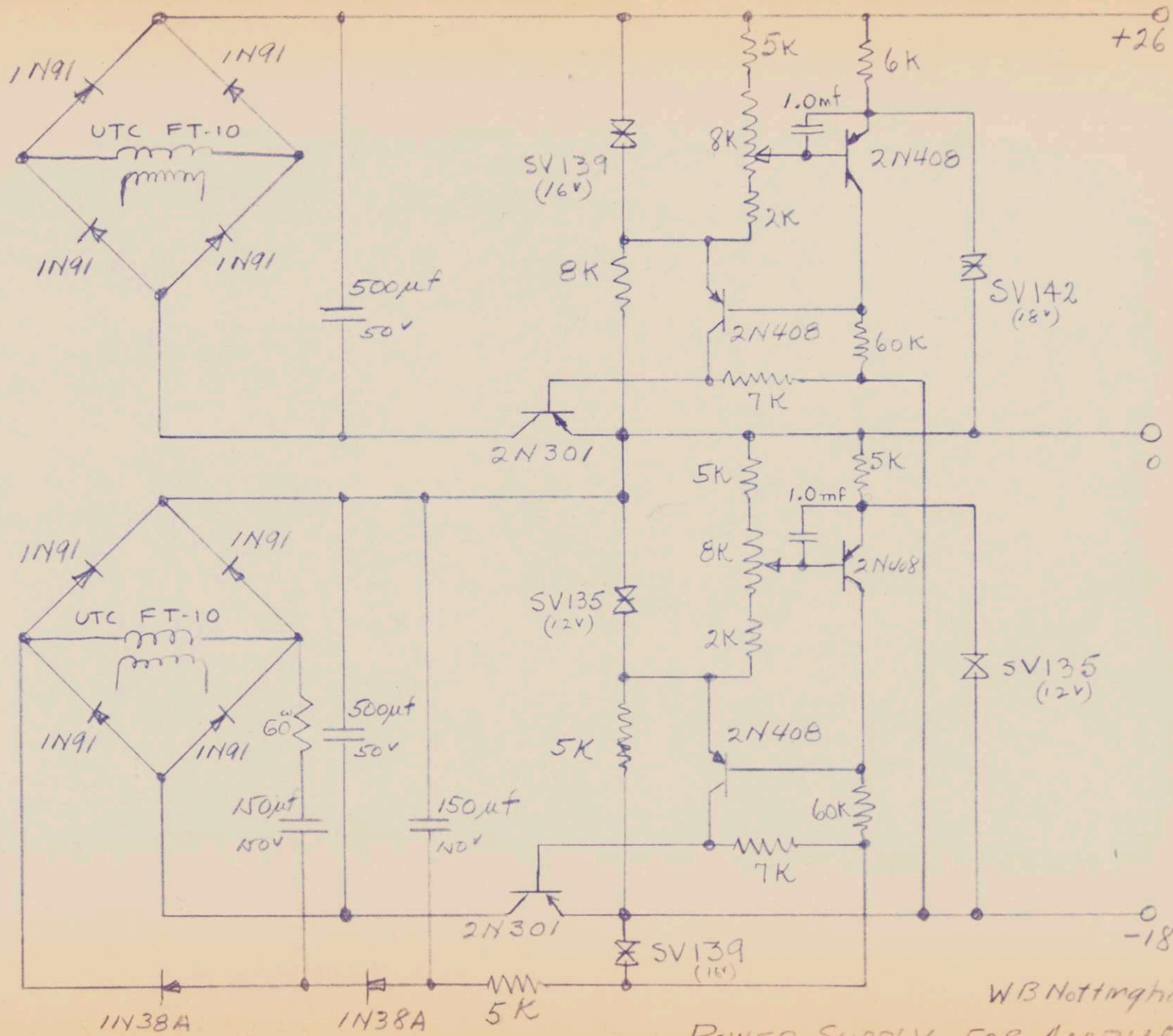

WB Nottingham
7/16/58
POWER SUPPLY FOR AMPLIFIER

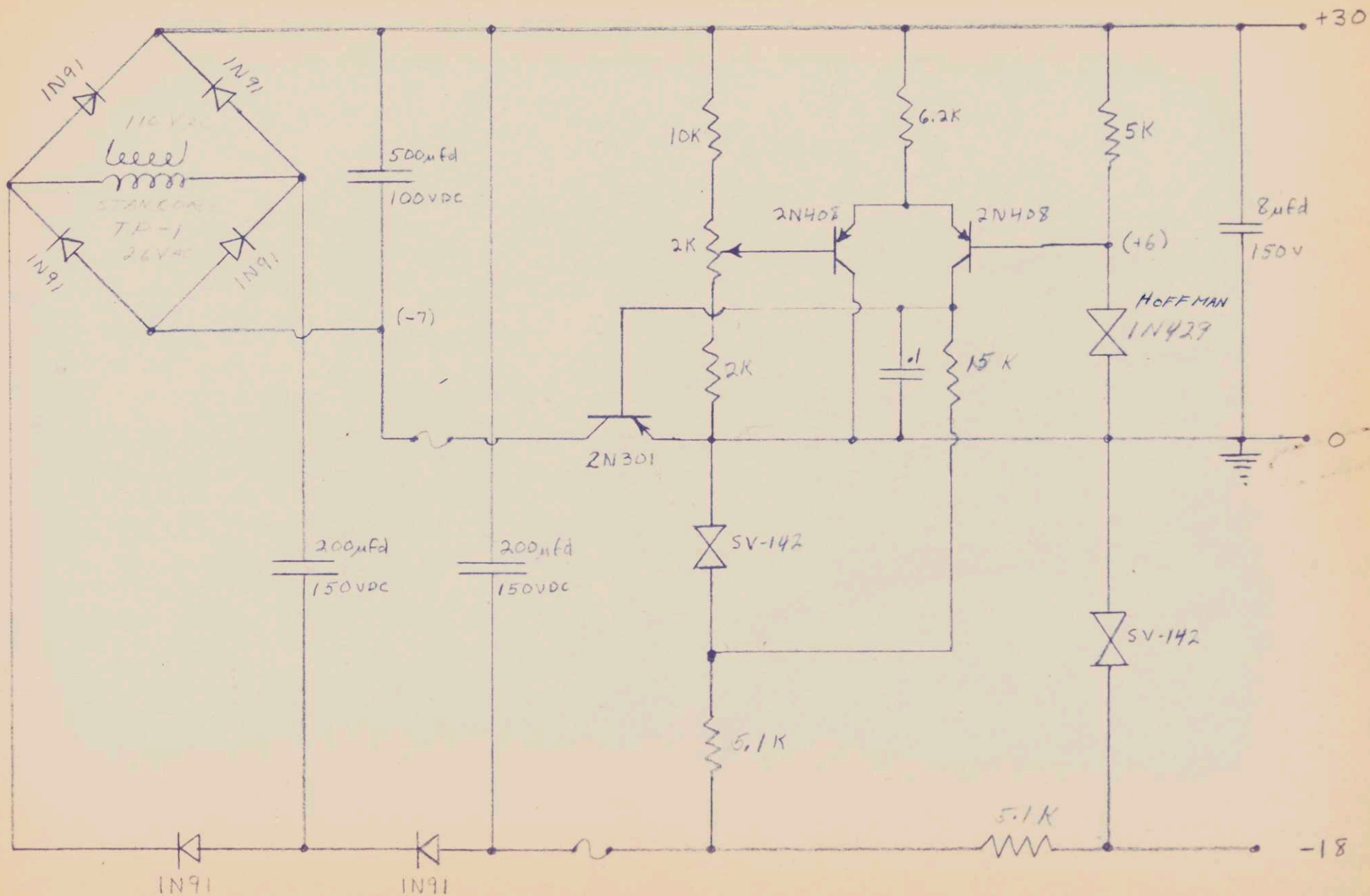

ELECTROMETER POWER SUPPLY

D. S. DUNAVAN
3 MARCH 1957

ELECTROMETER INPUT CIRCUIT

(NO CALIBRATION ADJUSTMENTS)

(NRC MODEL)

MASSACHUSETTS INSTITUTE OF TECHNOLOGY

.....19.....

Memo to.....

Room.....

Ext.....

from.....

Room.....

Ext.....

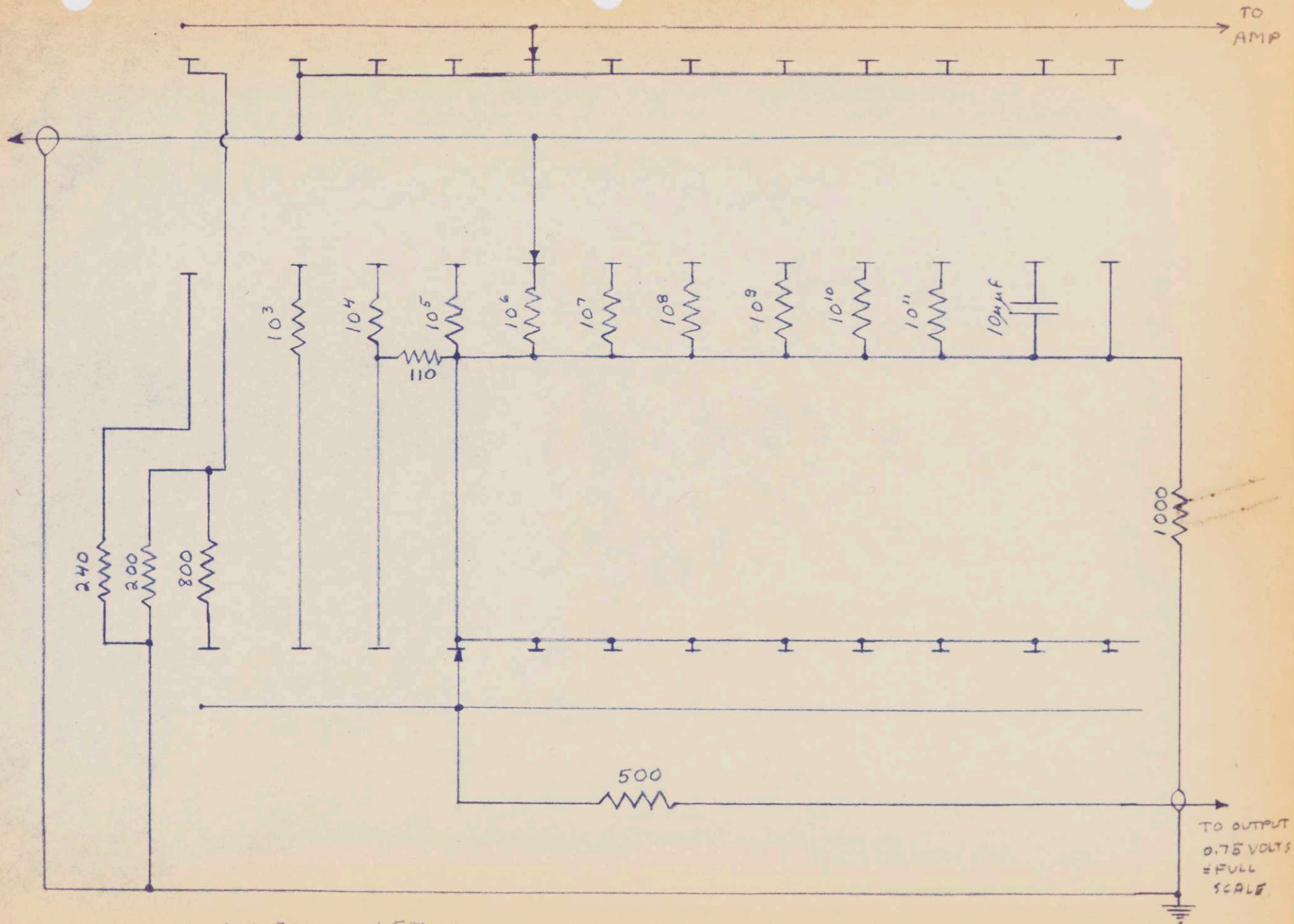

240, 200, 800 Ω ± 5% 1WATT
 10³-10⁷ ± 1%
 10⁸-10¹¹ ± 2%
 500, 1000, 110 Ω ± 1%

ELECTROMETER INPUT CIRCUIT
 D. S. DUNAVAN
 1 MAR 1959

June 25 '58

WB Nottingham

Pots $\pm 5\%$
 Res $\pm 5\%$ marked * cap $\pm 1\%$
 " 10^8 thru $10^{12} \pm 10\%$
 " All others $\pm 0.2\%$

Shield not
 connected to case
 Two positions
 on switch
 non shorting

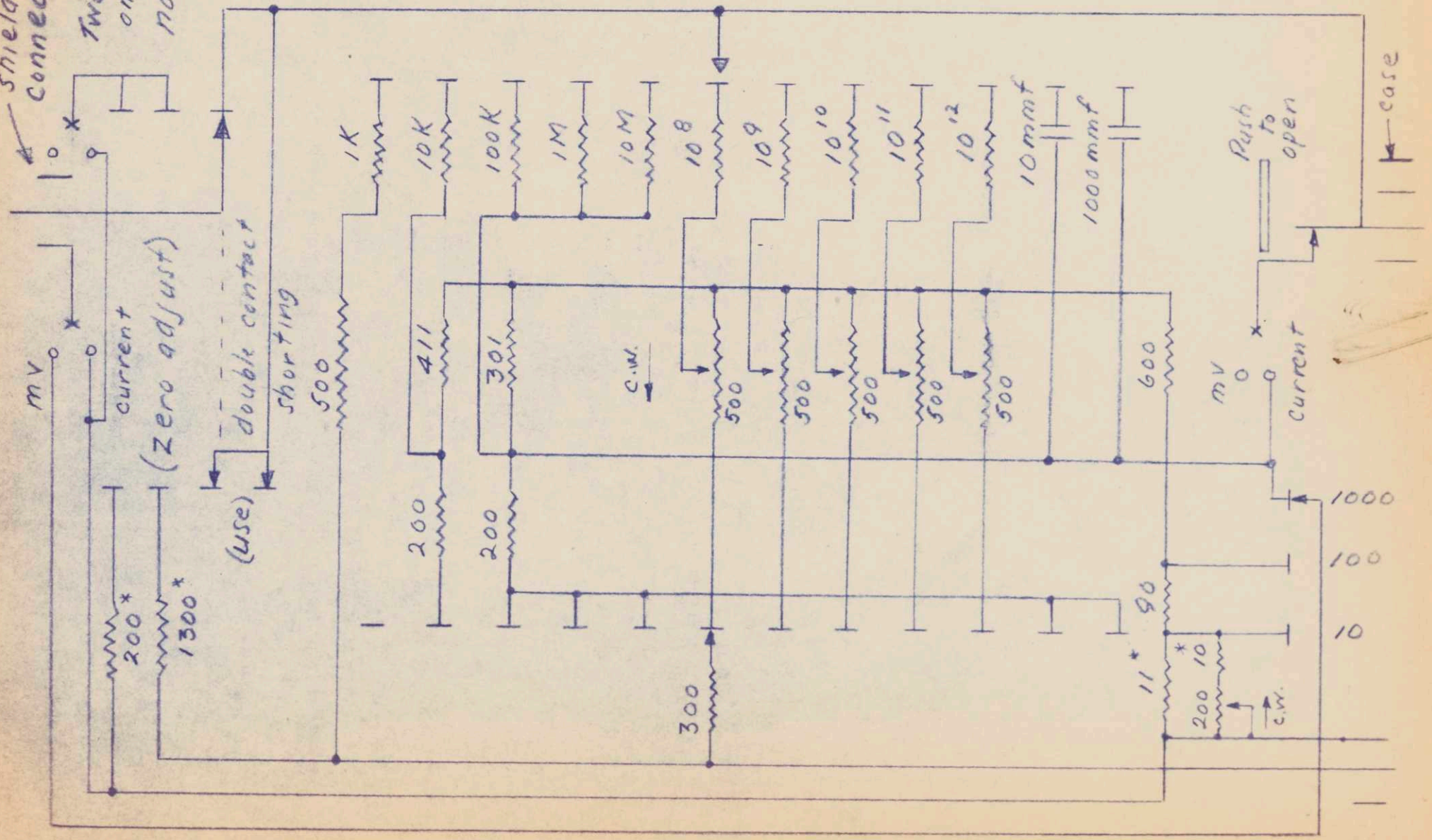

CHARACTERISTIC DATA
FOR Tubes USED IN
ELECTROMETER AMPLIFIER —

CX 5886

~~CX~~ 526 AX

MASSACHUSETTS INSTITUTE OF TECHNOLOGY

.....19.....

Memo to.....

Room.....

Ext.....

from.....

Room.....

Ext.....



SUBMINIATURE ELECTROMETER PENTODE

AVERAGE TRANSFER CHARACTERISTICS



RAYTHEON MANUFACTURING COMPANY

RECEIVING AND CATHODE RAY TUBE OPERATIONS



Excellence in Electronics

TYPE CK5886

The CK5886 is an electrometer pentode of subminiature construction having extremely low filament current, high emission stability and low microphonics. Operated as a triode, the tube has an unusually high ratio of transconductance to control grid current for single stage circuits. As a pentode, the amplification factor is high enough to afford considerable voltage gain in the electrometer stage of a multi-stage circuit. The flexible terminal leads may be soldered or welded directly to the terminals of circuit components without the use of sockets. Standard inline subminiature sockets may be used by cutting the leads to a suitable length.

MECHANICAL DATA

ENVELOPE: T-2 X3 Glass

BASE: Pinch Press (0.016" tinned flexible leads. Length: 1.5" min. Spacing: Leads 4-7 0.144" center-to-center; Other Leads: 0.048" center-to-center.)

DIMENSIONS:

Maximum Overall Length
Maximum Width
Maximum Thickness

1.5 inch
0.400 inch
0.285 inch

TERMINAL CONNECTIONS: (Red Dot is adjacent to Lead 1)

Lead 1 Plate
Lead 2 Screen Grid
Lead 3 Filament, Positive; One Deflector
Lead 4 Filament, Negative; One Deflector
Lead 7 Control Grid

MOUNTING POSITION: Any

ELECTRICAL DATA

DIRECT INTERELECTRODE CAPACITANCES: (pfd.)

Control Grid to All
Control Grid to Screen Grid and Plate

Unshielded
2.2
2.0

RATINGS - ABSOLUTE MAXIMUM VALUES:

Filament Voltage (dc)
Plate Voltage
Screen Grid Voltage
Total Cathode Current

1.25 ± 20% volts
22.5 volts
22.5 volts
300 μAdc

CHARACTERISTICS AND TYPICAL OPERATION:

Filament Voltage
Filament Current
Plate Voltage
Screen Grid Voltage
Control Grid Voltage
Plate Current
Screen Grid Current
Amplification Factor
Transconductance
Plate Resistance (approx.)
Maximum Control Grid Current
Nominal Control Grid Current

Table with columns for Triode and Pentode characteristics, including filament voltage, current, plate voltage, screen grid voltage, control grid voltage, plate current, screen grid current, amplification factor, transconductance, plate resistance, maximum control grid current, and nominal control grid current.

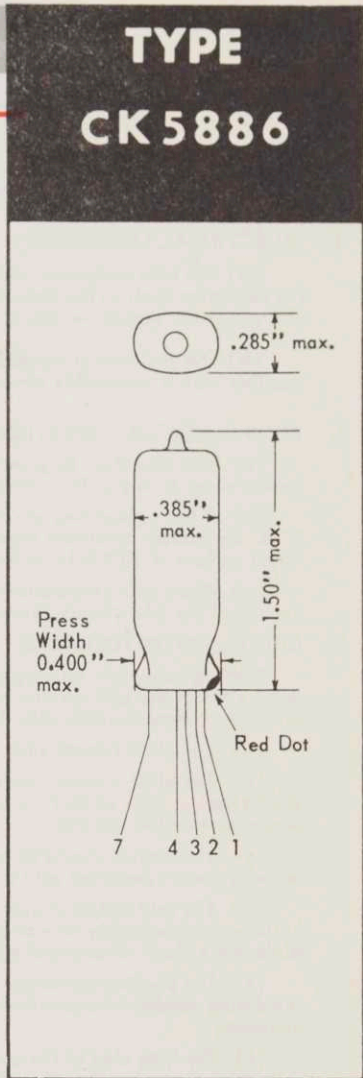

DF 703

- For use with batteries having an initial voltage of 1.55 volts max.
■ Screen Grid connected to plate

Tentative Data

RAYTHEON MANUFACTURING COMPANY

RECEIVING AND CATHODE RAY TUBE OPERATIONS



SUBMINIATURE ELECTROMETER PENTODE

NOTES ON GRID CURRENT MEASUREMENTS *

1. ELECTRICAL CONDITIONS:

(a) The tube under test should be supplied with rated plate voltage, screen voltage, filament voltage and control grid bias, with the exception that, in the case of an operational condition aimed at the lowest possible grid current, it is preferable to fix the bias and adjust the screen voltage to give the required plate current within the limits of 3.0 to 6.0 volts, E_{sg} .

(b) The stability of the supply potentials (including temperature stability) should be consistent with the expected grid current level together with a reasonable measuring time for a grid current determination. (See 3-d)

2. ENVIRONMENTAL CONDITIONS:

(a) The tube must be shielded from electric and magnetic fields as well as from all forms of radiant energy, including light, gamma rays, X-rays, Grenz rays and high-energy particles such as deuterons, protons and electrons.

(b) If the surrounding gas is at atmospheric pressure or approximately so, the relative humidity should be no higher than 20%. No surface treatment known (including dri-film, ceresin wax, etc., etc.) is as effective, at 50% or higher R.H., as a clean surface at 20% R.H. or less.

(c) Where drift is important, the temperature coefficients of other components, particularly the dielectrics in the exterior portion of the grid circuit, is usually the limiting factor rather than any temperature effects of the tube itself.

3. GRID RESISTOR TECHNIQUE

Although complete information must be available concerning the temperature coefficient, voltage coefficient and polar characteristics of the grid resistor used, this method is never the less the most convenient for a grid current measurement of a precision commensurable with the measuring time. Certain precautions, however, should be observed:

(a) The plate current shift should be measured when the grid resistor is shorted out.

(b) The plate current, upon cutting the resistor into the circuit, should be allowed either (1) at least five minutes to stabilize or (2) time enough so that the drift, referred to the grid, is not much more than one or two millivolts per minute. This latter presupposes that the resistor is 10^{12} ohms and the expected grid current is 1 or 2×10^{-15} amps.

(c) The circuit should be arranged, if possible, so that C- (rather than A-) is grounded. This allows the use of a grounded resistor switch designed with a minimum of insulation.

(d) The grid circuit should be "padded" with a capacitance of the order of 20 or 25×10^{-12} F. Values appreciably higher than this build up an intolerable time constant while lower values begin to give considerable trouble from polar phenomena due to charges left on dielectrics (both interior and exterior to the tube) by the switching transient

(e) The padding condenser should be designed so that at least 90% of its total capacitance is across an air dielectric, with the insulating member in a relatively weak part of the field. Such a design will reduce polar phenomena at this point to an irreducible minimum.

(f) The high side of the grid circuit should be grounded before opening the enclosure to change the tube under test. The relaxation times for dielectric absorption and decay currents associated with these dielectrics (including the grid resistor itself which is virtually a semi-conductor) are such that the mere act of touching an ungrounded circuit can (and often does) leave a charge which, in terms of millivolts, requires several hours to decay completely.

4. GRID CAPACITANCE TECHNIQUE

The classical method of determining grid current by measuring the absolute value of the grid capacitance and using this value together with the transconductance and the rate of change of the plate current as in:

$$C dE_g = T dI_p$$

is not recommended. At extremely low grid currents (10^{-15} amperes or less) polar phenomena cannot be separated from the charge being measured without observational studies extending into hours if not days while at slightly higher currents more direct methods are preferable

5. CLEANING

Tubes subjected to excessive handling should be re-cleaned at the time of the grid current test. For this purpose alcohol is adequate unless severe contamination is suspected, in which case the alcohol dip may be preceded by other well-known glass cleaning agents. The container for the alcohol should be deep enough to allow dust, etc., from previous tubes to settle.

6. GENERAL

No tube of this class can be expected to show rated grid current in a few minutes of operation following a protracted period (a few weeks) of idleness. A re-distribution of residual gas molecules takes place when the filament is first raised to the temperature of operation and the practical result is an exponential decline of grid current with a time constant depending on:

- (a) Total time the tube has been operated.
- (b) Time since last operation.
- (c) Required operating grid current level.

In equipments entailing the most exacting requirements, continuous operation is recommended.

* These notes are particularly applicable to the pentode connection.



SUBMINIATURE ELECTROMETER PENTODE

ELECTROMETER CIRCUIT BIBLIOGRAPHY

1. A Feedback Micromicroammeter	RSI, June 1939	S. Roberts
2. A Feedback D-C Meter	Electronics, Sept. 1938	J. M. Brumbaugh & A. W. Vance
3. Electrometer Input Circuits	Electronics, Dec. 1946	H. A. Thomas
4. An Improved Vacuum Tube Microammeter	RSI, Dec. 1936	A. W. Vance
5. An Improved D-C Amplifier for Portable Ionization Chamber Instruments	RSI, Apr. 1951	N. F. Moody
6. Improvements in the Stability of the F P-54 Electrometer Tube	Jour. of App. Physics, Nov. 1945	J. M. Lafferty & K. H. Kingdon
7. Direct-Current Amplifier Circuits for Use with the Electrometer Tube	RSI, Apr. 1935	D. B. Penick
8. An Improved Balanced Circuit for Use with Electrometer Tubes	RSI, Aug. 1933	L. A. Turner & C. O. Siegelin
9. A Balanced Electrometer Tube and Amplifying Circuit for Small Direct Currents	RSI, Apr. 1934	G. P. Harnwell & S. N. Van Voorhis
10. An Improved D-C Amplifying Circuit	RSI, Oct. 1933	L. A. DuBridgE & H. Brown

N. B. References 1 to 5 deal with feedback circuits in which considerable gain is realized in the electrometer input stage. References 6 to 10 are concerned with the classical type of balanced circuit working directly into the galvanometer. The CK5889 cannot be operated at low control grid currents in the space-charge connection because the amplification factor, G_2 to P, is much too high (approximately 125).

AVERAGE PLATE CHARACTERISTICS (Triode Connected)

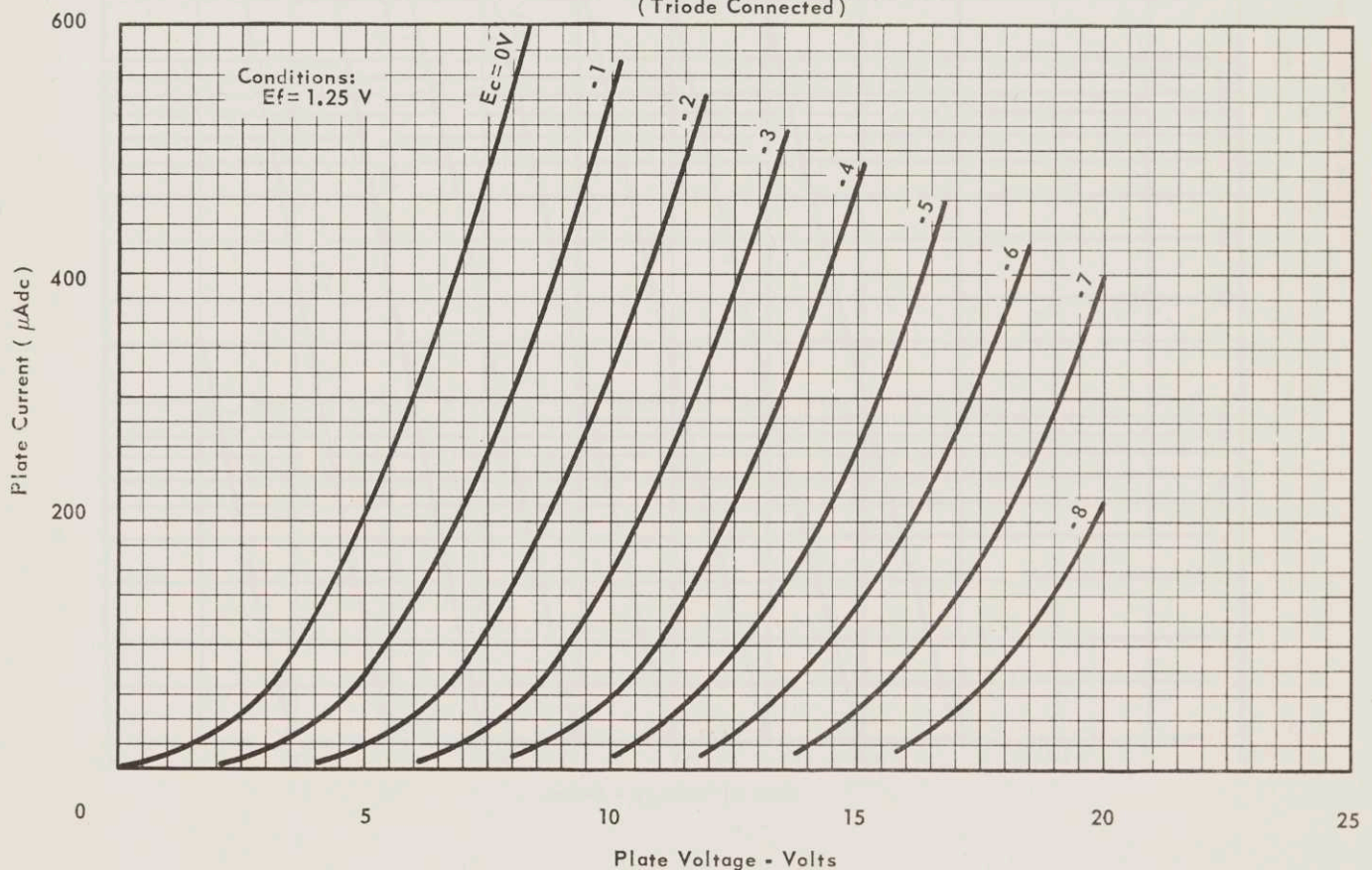



SUBMINIATURE ELECTROMETER PENTODE

AVERAGE TRANSFER CHARACTERISTICS
(Pentode Connected)

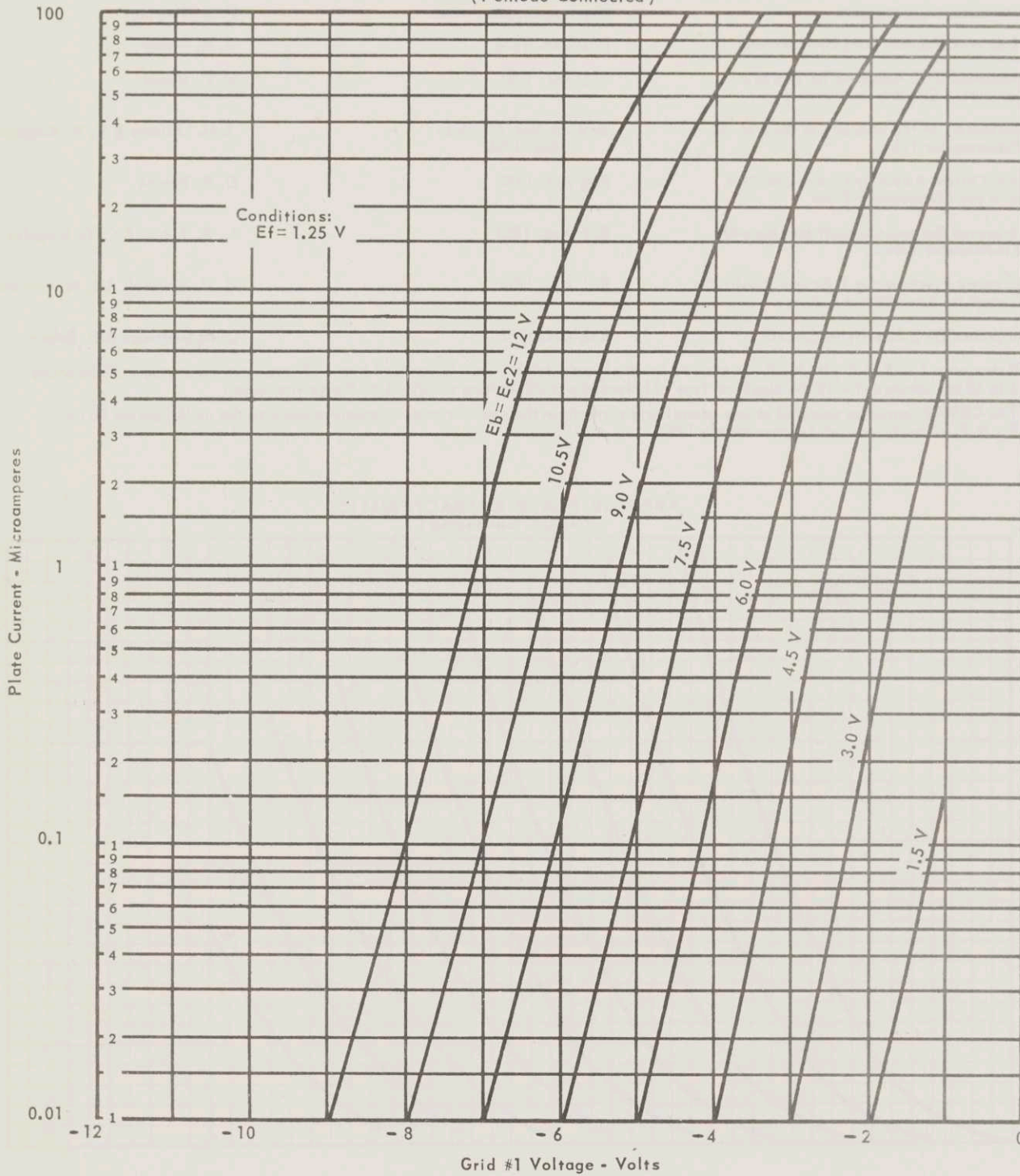

RAYTHEON MANUFACTURING COMPANY
RECEIVING AND CATHODE RAY TUBE OPERATIONS



SUBMINIATURE ELECTROMETER PENTODE

AVERAGE TRANSFER CHARACTERISTICS
(Triode Connected)

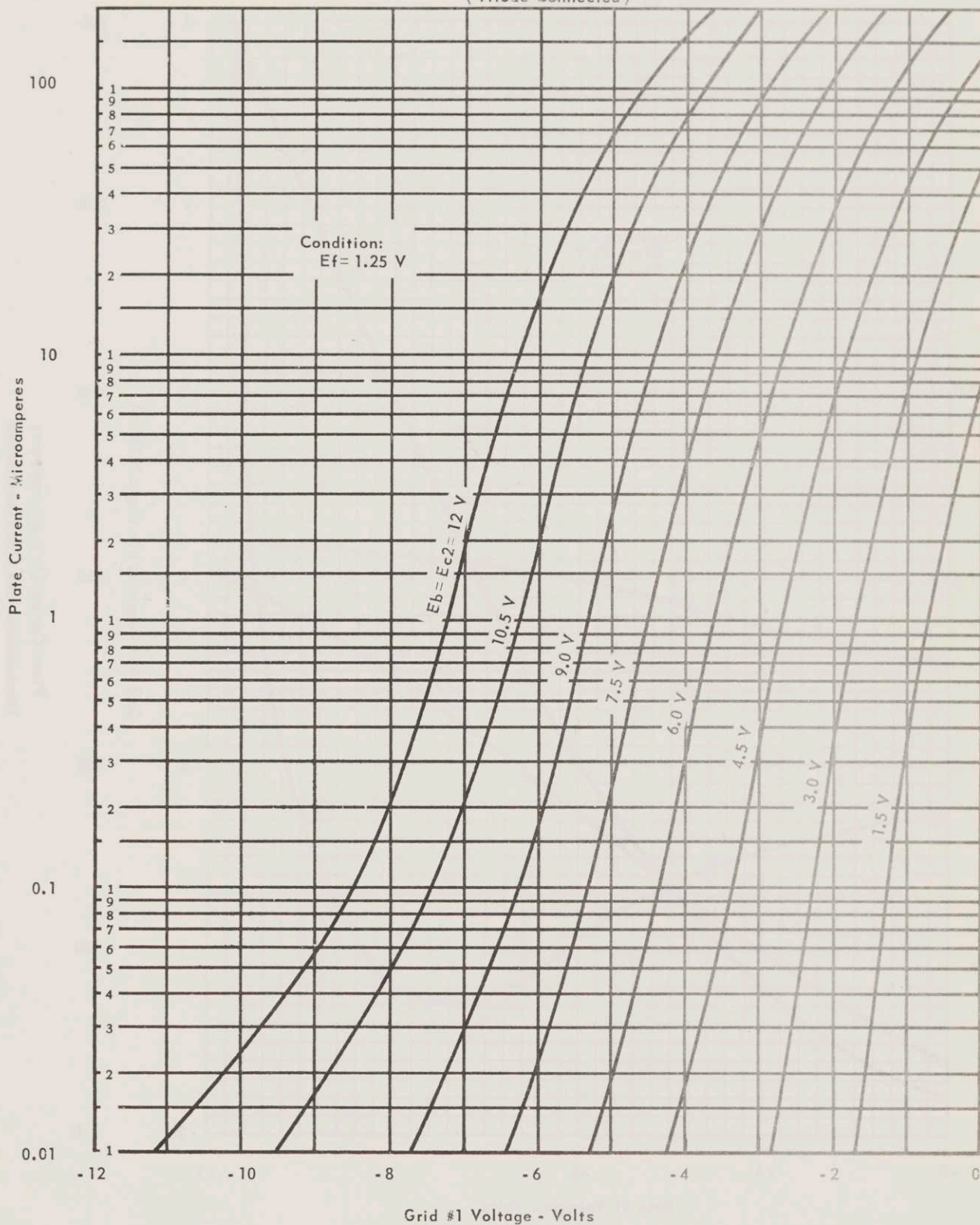



SUBMINIATURE ELECTROMETER PENTODE

AVERAGE TRANSFER CHARACTERISTICS
(Triode Connected)

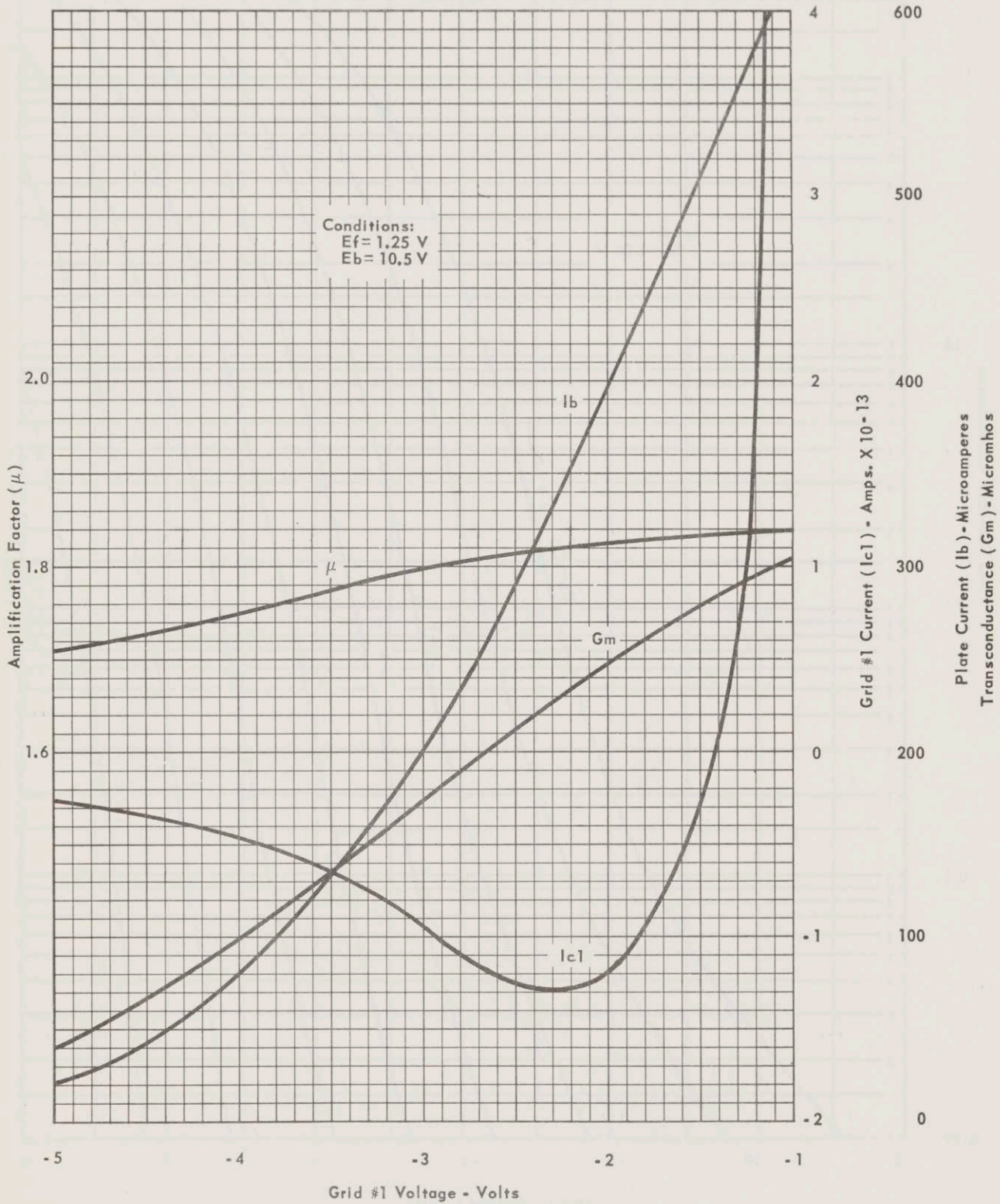

RAYTHEON MANUFACTURING COMPANY
RECEIVING AND CATHODE RAY TUBE OPERATIONS



SUBMINIATURE ELECTROMETER PENTODE

AVERAGE TRANSFER CHARACTERISTICS
(Triode Connected)





AVERAGE PLATE CHARACTERISTICS

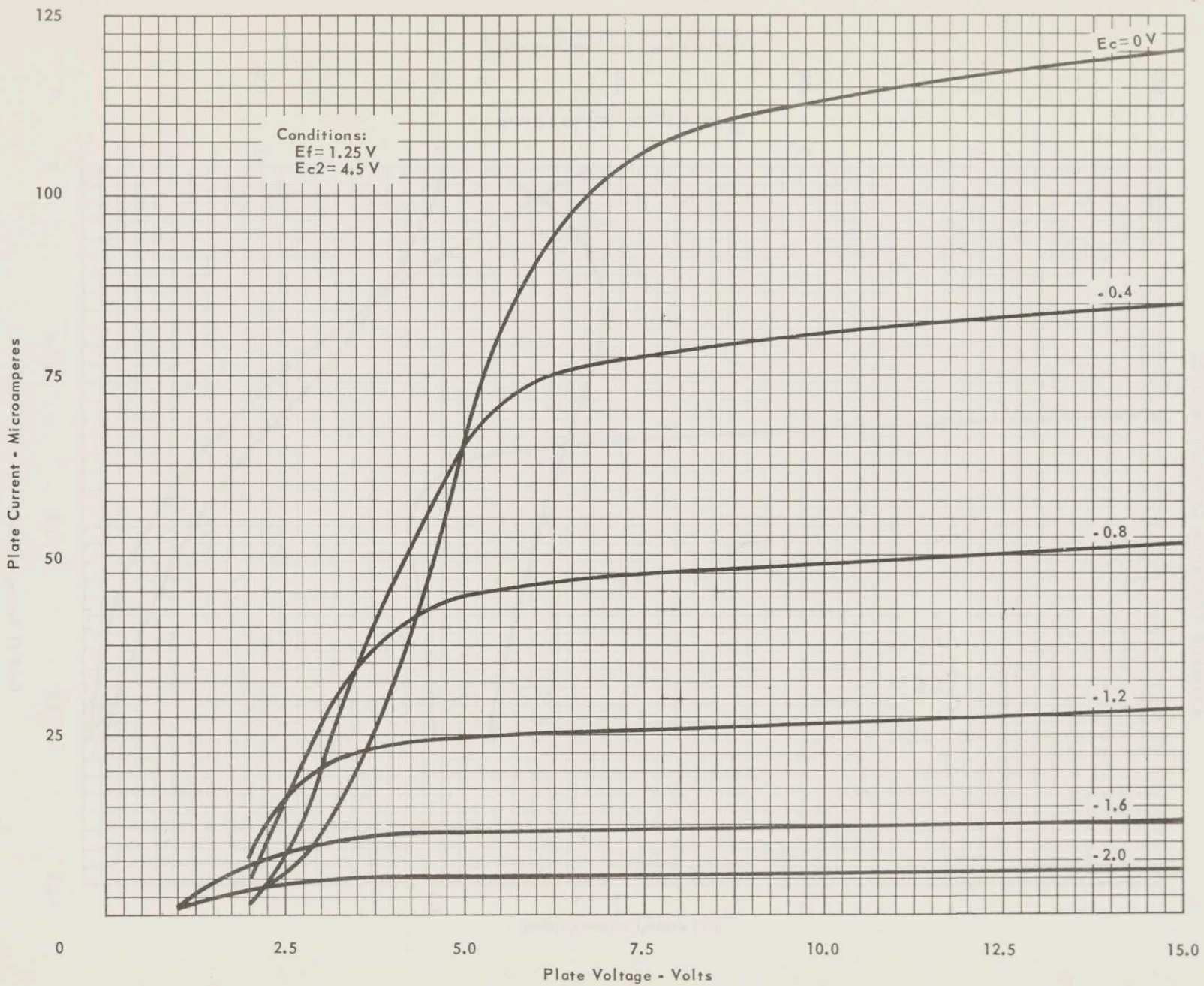



TYPE CK5886

SUBMINIATURE ELECTROMETER PENTODE

AVERAGE PLATE CHARACTERISTICS

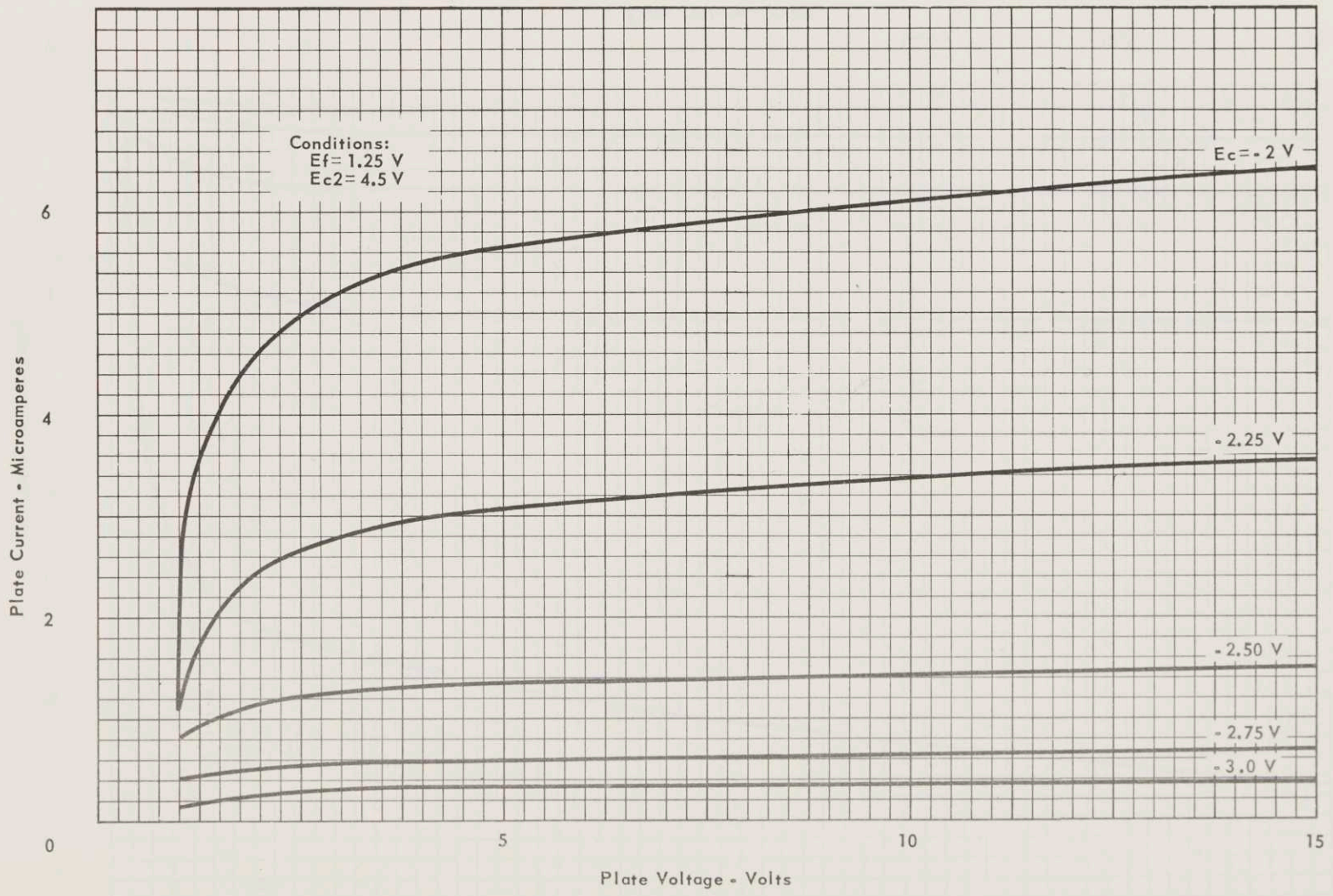

Printed in U.S.A.

RAYTHEON MANUFACTURING COMPANY

RECEIVING AND CATHODE RAY TUBE OPERATIONS

August 1, 1956

NEWTON 58, MASS.

Page 9 of 12



AVERAGE PLATE CHARACTERISTICS

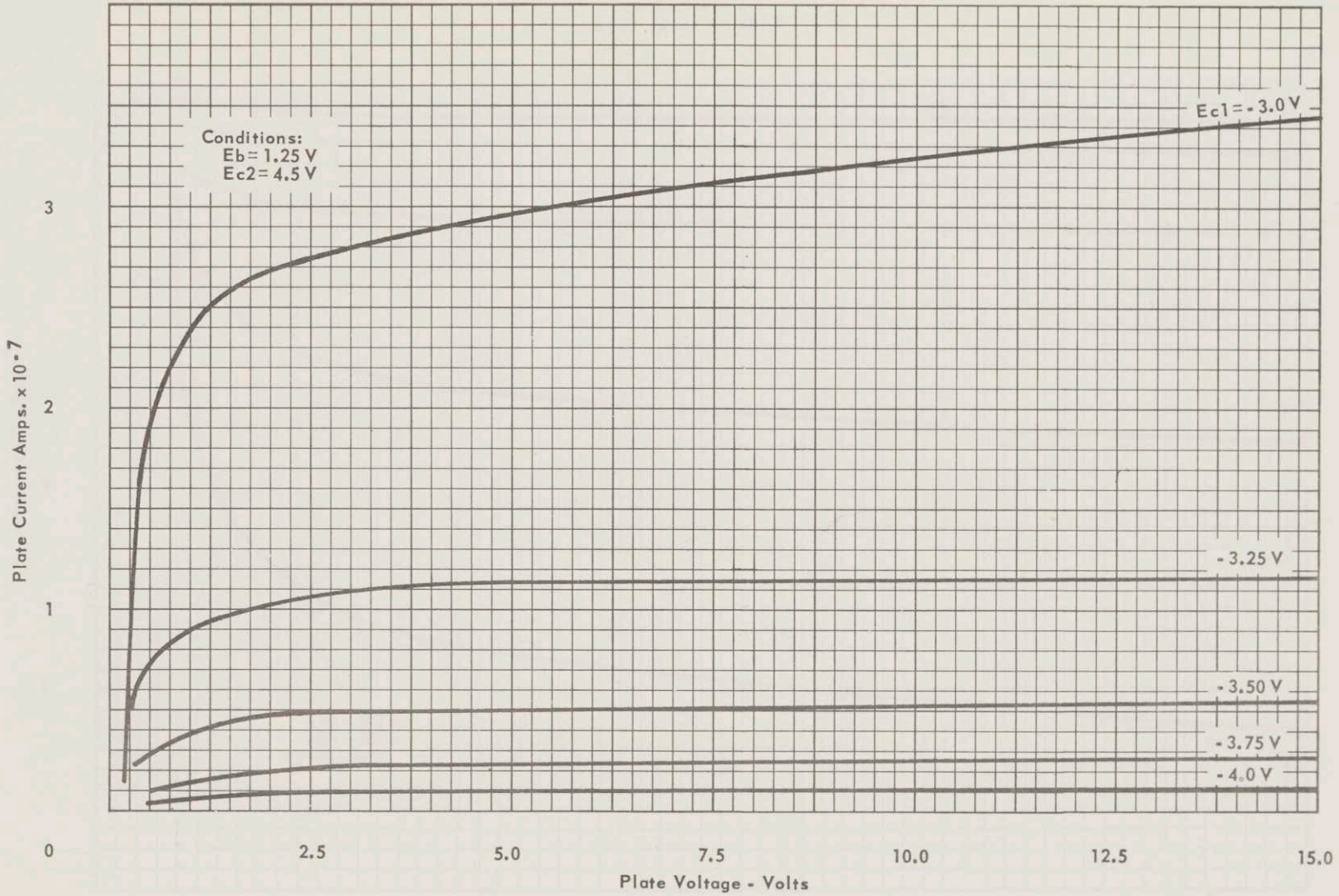



SUBMINIATURE ELECTROMETER PENTODE

GRID CURRENT vs. GRID TO PLATE POTENTIAL
Triode Connected
(Grid #2 Tied to Plate)

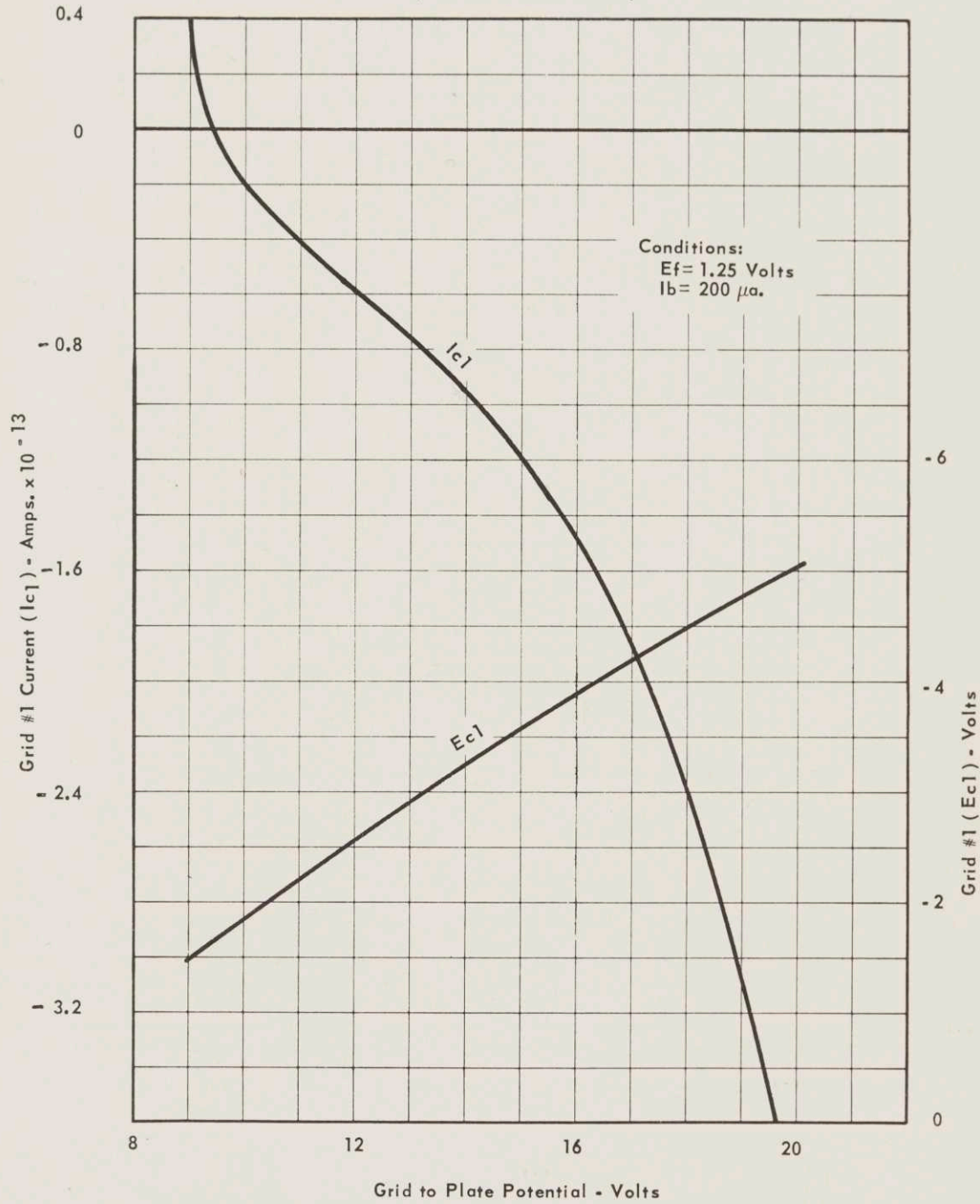

JUNE 1951



RAYTHEON MANUFACTURING COMPANY

RECEIVING AND CATHODE RAY TUBE OPERATIONS



RAYTHEON MANUFACTURING COMPANY

RECEIVING AND CATHODE RAY TUBE OPERATIONS

NEWTON 58, MASS.

Line 3141

SV-124

Silicon avalanche

5.7 V }
6.3 V } 6V

10 ma

6 W at 10 ma.

250 mV

.03 %/°C

TYPE
CK526AX

The CK526AX is a filament type pentode of subminiature construction designed for use as a power amplifier in portable and wearable equipment. The rinned flexible leads may be soldered or welded directly to the terminals of circuit components without the use of sockets. Standard inline subminiature sockets may be used by cutting the leads to a suitable length.

MECHANICAL DATA

ENVELOPE: T-2X3 Glass

BASE: None (0.016" rinned flexible leads. Length: 1.5" min.
Spacing: 0.028" center-to-center)

TERMINAL CONNECTIONS: (Red Dot is adjacent to Lead 1)

Lead 1 Plate	Lead 4 Control Grid
Lead 2 Screen Grid	Lead 5 Filament, Negative Φ
Lead 3 Filament, Positive Φ	

MOUNTING POSITION: Any

ELECTRICAL DATA

RATINGS - ABSOLUTE MAXIMUM VALUES:

Filament Voltage (dc)	1.25 \pm 20% volts
Plate Voltage	45 volts
Screen Grid Voltage	45 volts
Cathode Current	1.0 ma.

CHARACTERISTICS AND TYPICAL OPERATION:

Filament Voltage (dc)	1.25 volts
Filament Current	20 ma.
Plate Voltage	22.5 volts
Screen Grid Voltage	22.5 volts
Control Grid Voltage	-1.5 volts
Peak AF Control Grid Voltage	1.5 volts
Plate Current	0.25 ma.
Screen Grid Current	0.12 ma.
Transconductance	400 μ mhos
Plate Resistance	0.22 meg.
Load Resistance	0.05 meg.
Distortion (approx.)	10 percent
Power Output	3.75 mw.

Φ Grid #2 is composed of two deflector plates, one being connected to Lead 1 and the other to Lead 4.

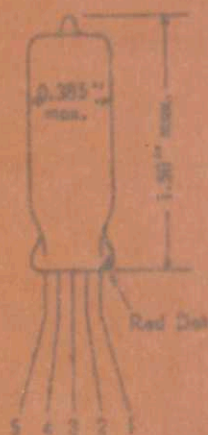
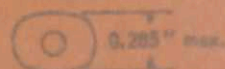



SUBMINIATURE PENTODE

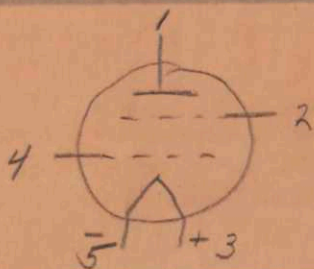

AVERAGE PLATE CHARACTERISTICS

For $E_{SG} = 16.5$ ACTUAL GRID BIAS MUST BE 1.0 Volts less than INDICATED ON CURVES below.

For $E_{SG} = 19.5$ subtract 0.5 Volts

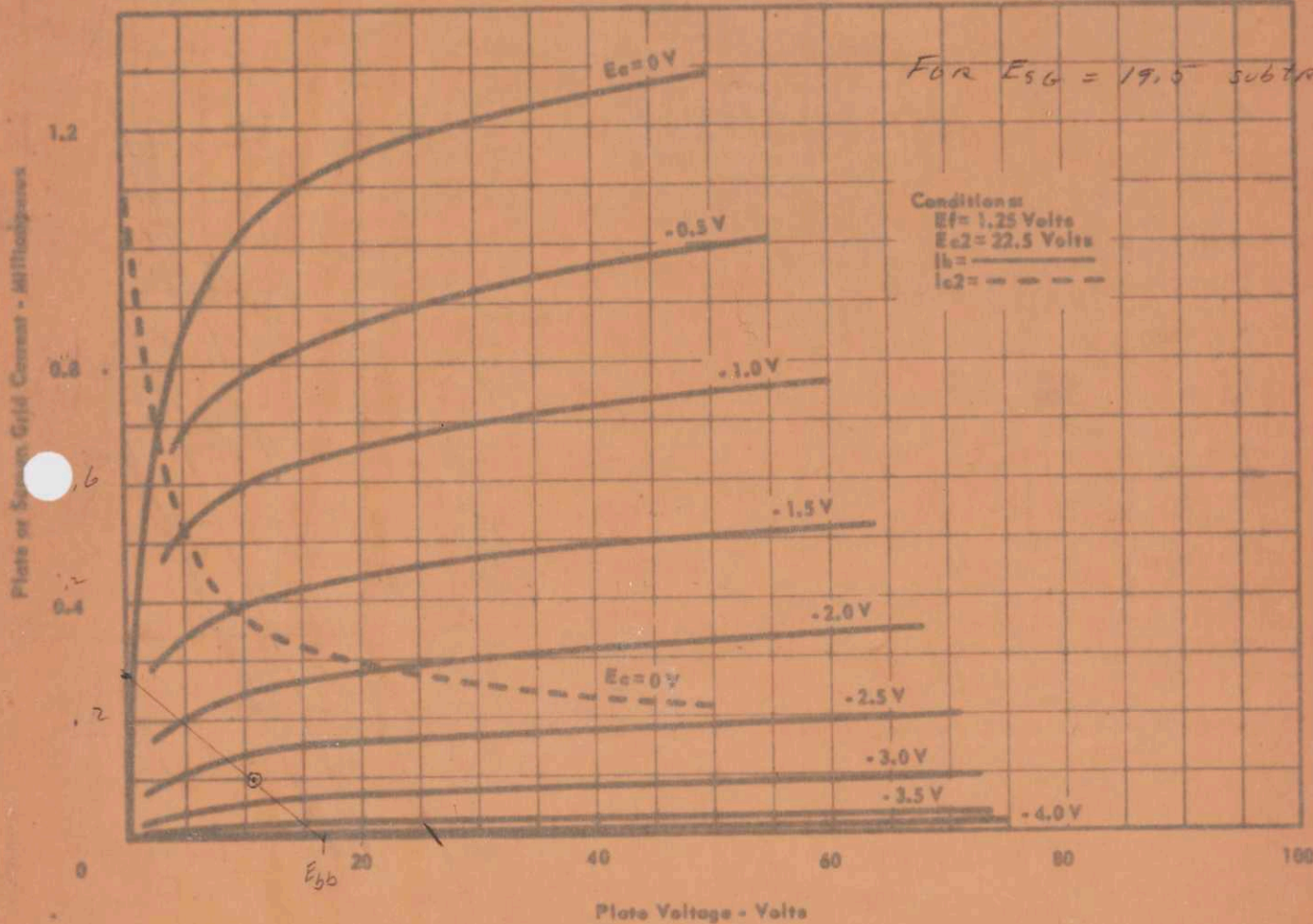

$$R_L = \frac{20}{8.5 \times 10^{-4}} = 23,500 \Omega$$

$$I_a = \frac{D}{60} \times 10^{-3}$$

RAYTHEON MANUFACTURING COMPANY

RECEIVING AND CATHODE RAY TUBE OPERATIONS

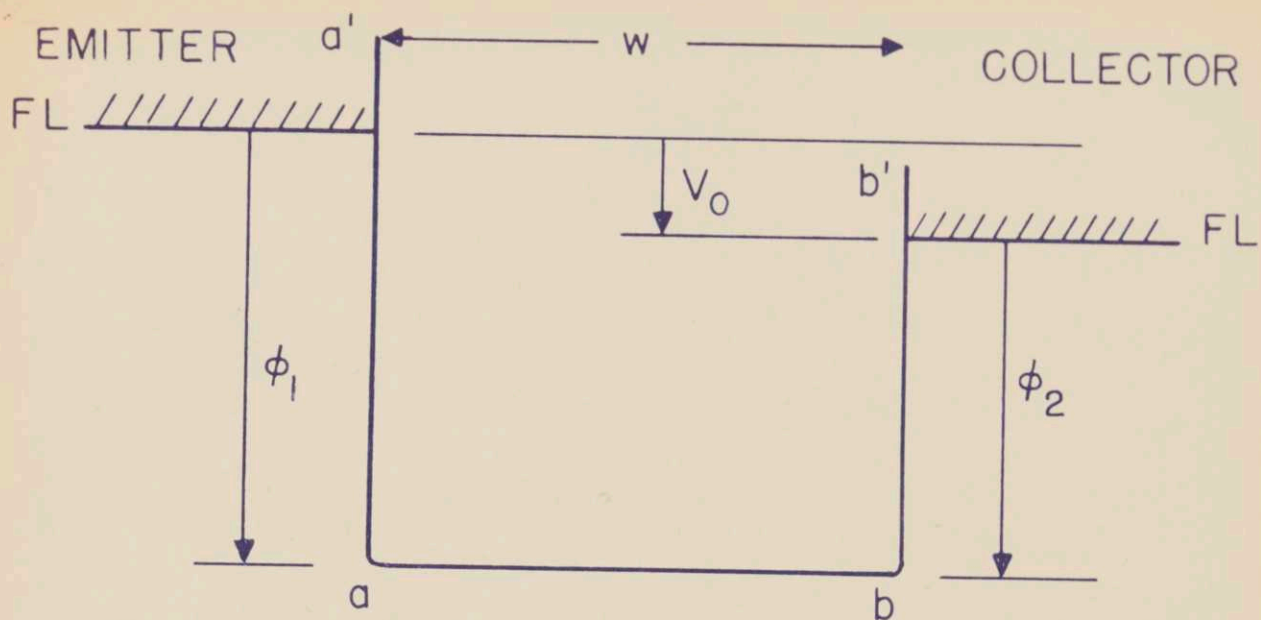

FIG. 1

MOTIVE OF AN ELECTRON WITH ZERO FIELD BETWEEN a and b

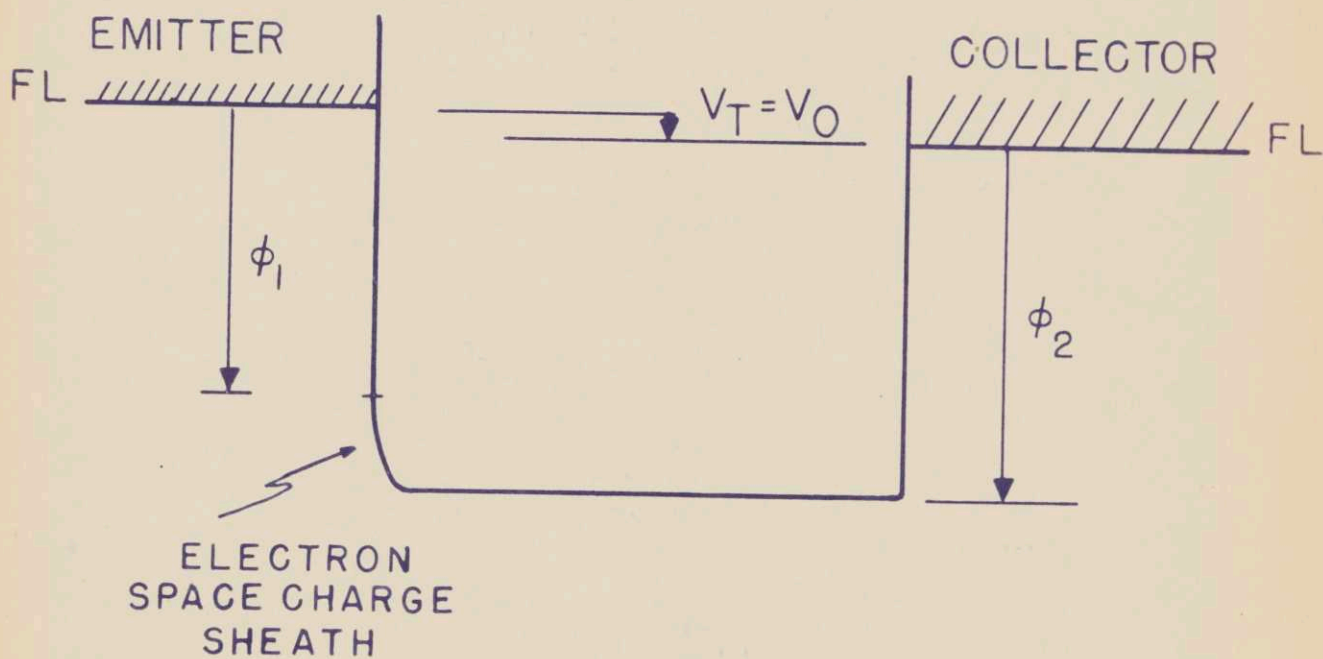

FIG. 2

PLASMA DIODE WITH HIGH COLLECTOR WORK-FUNCTION

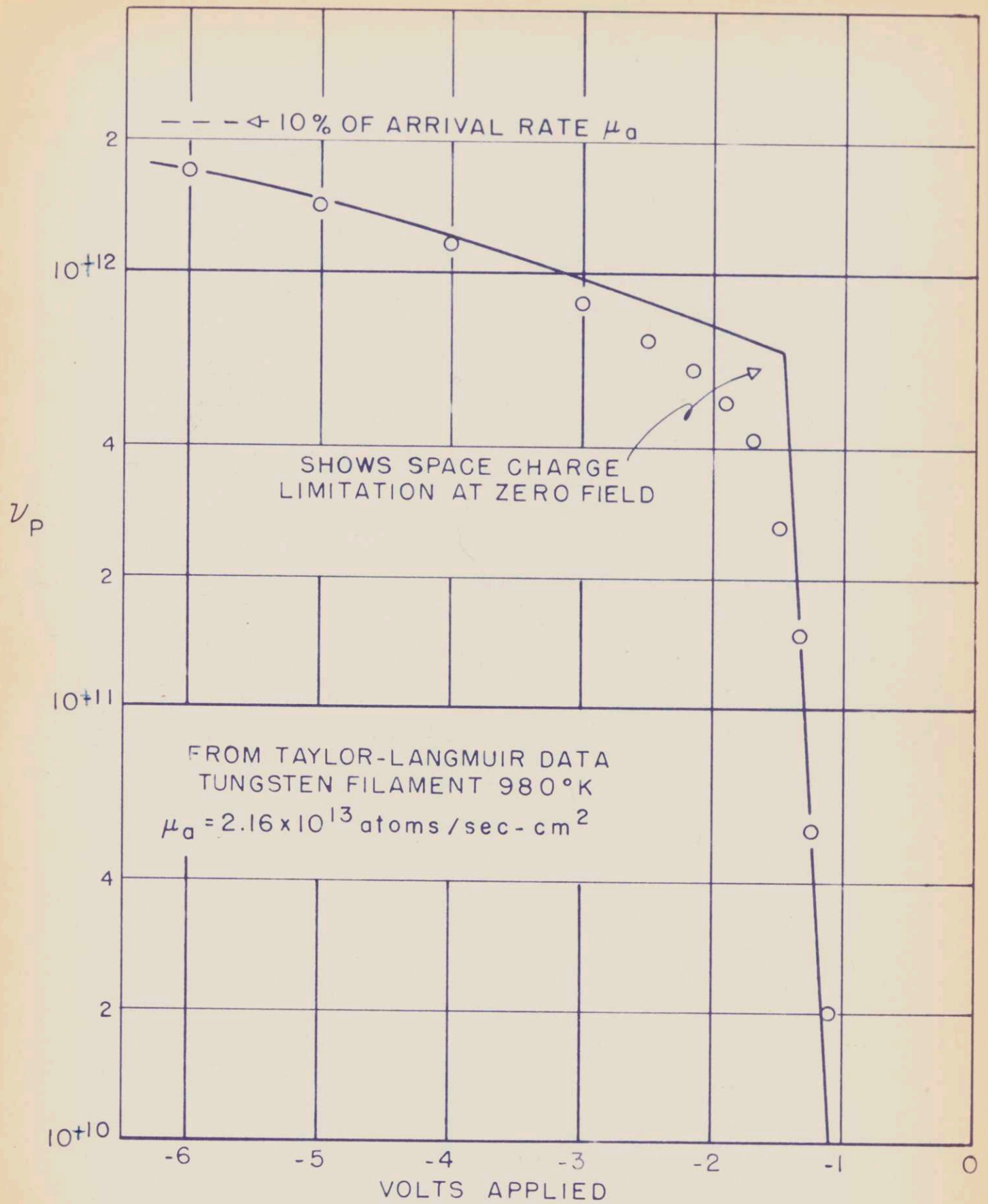

Fig. 3

Ionization rate as a function of applied volts observed by Taylor and Langmuir.

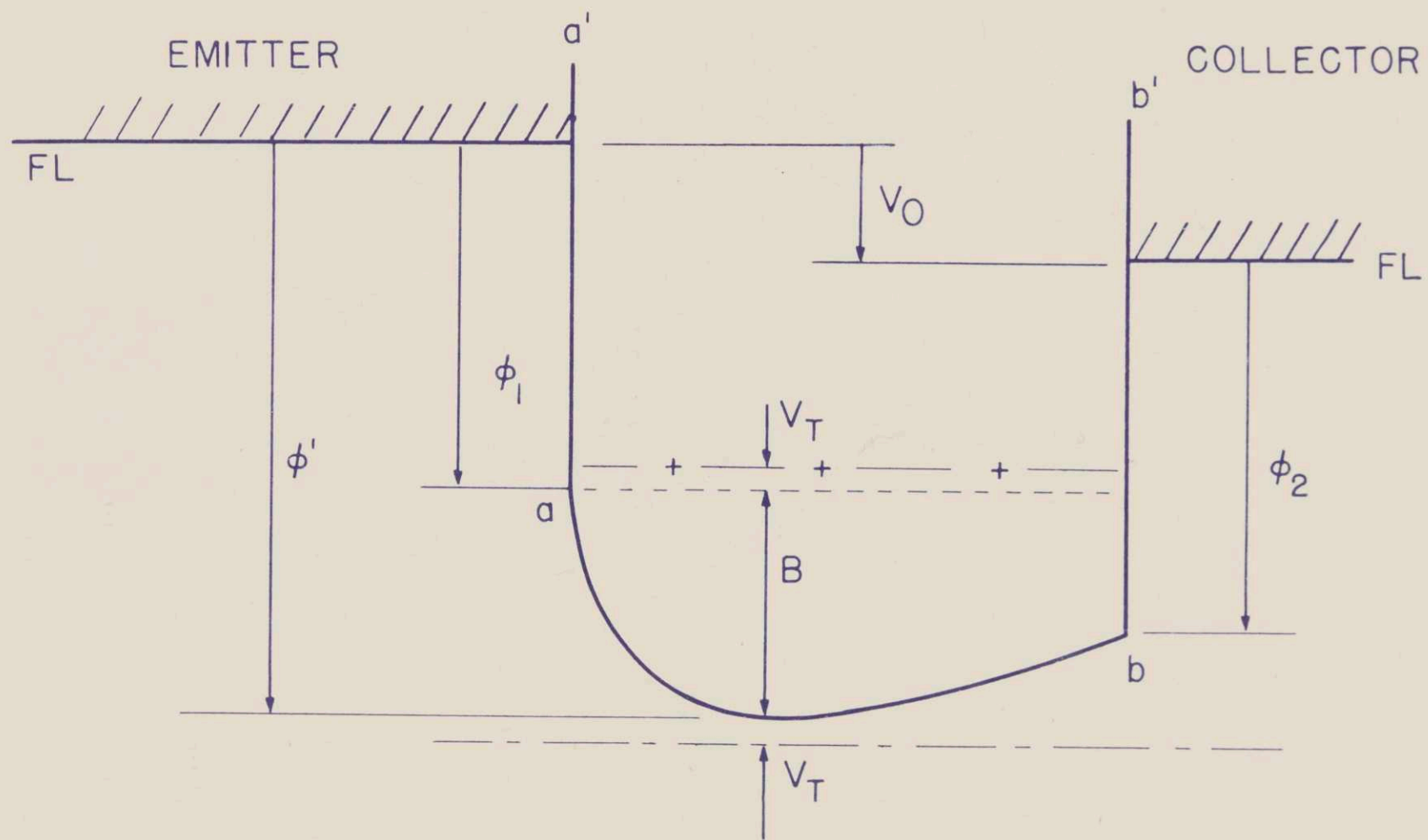

Fig. 4

Motive curve with electron space charge.

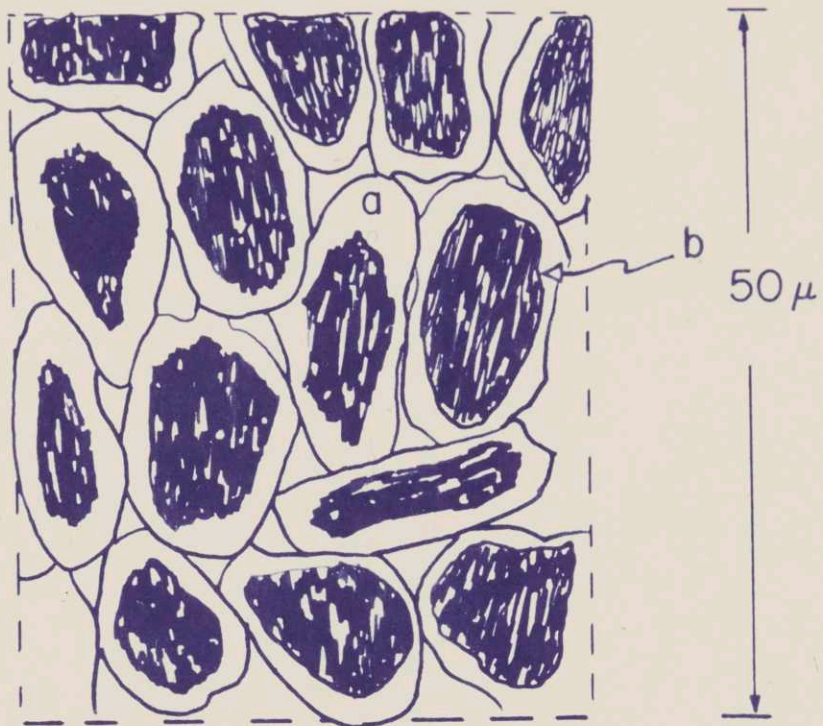

Fig. 5

Hypothetical electron emission distribution over the surface of a very hot dispenser cathode.

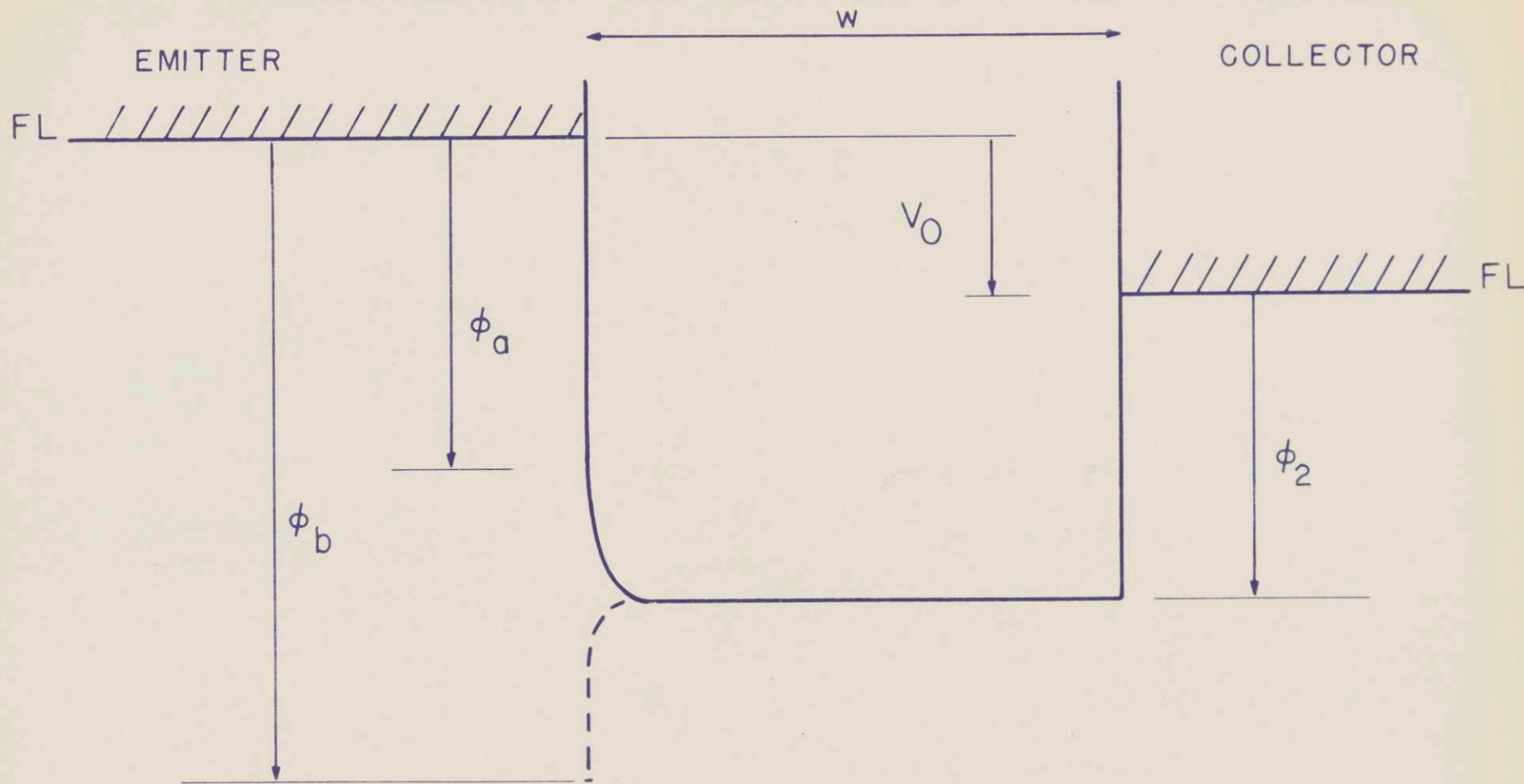

FIG. 6
 MOTIVE CURVES FOR NON-UNIFORM
 EMITTER — NO SPACE CHARGE — ZERO FIELD

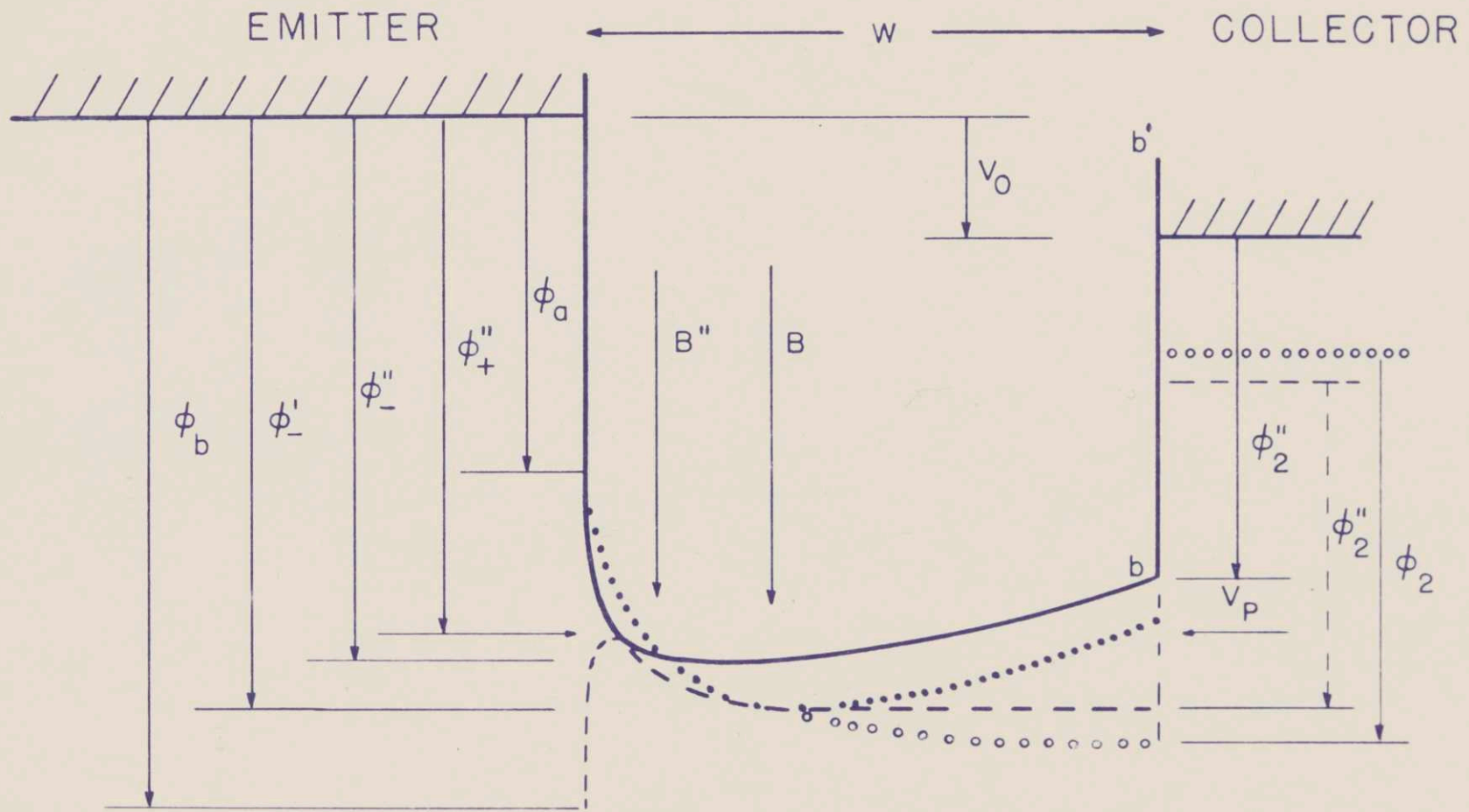

Fig. 8

Motive functions plasma diode compared with vacuum diode.

Zero-field - - - (plasma) ○○○○○ (vacuum)
 Max power ——— (plasma) ●●●●● (vacuum)

Fig. 9

Experimental results and comparison with space-charge theory for vacuum diode. Data from Robinson of TEE.

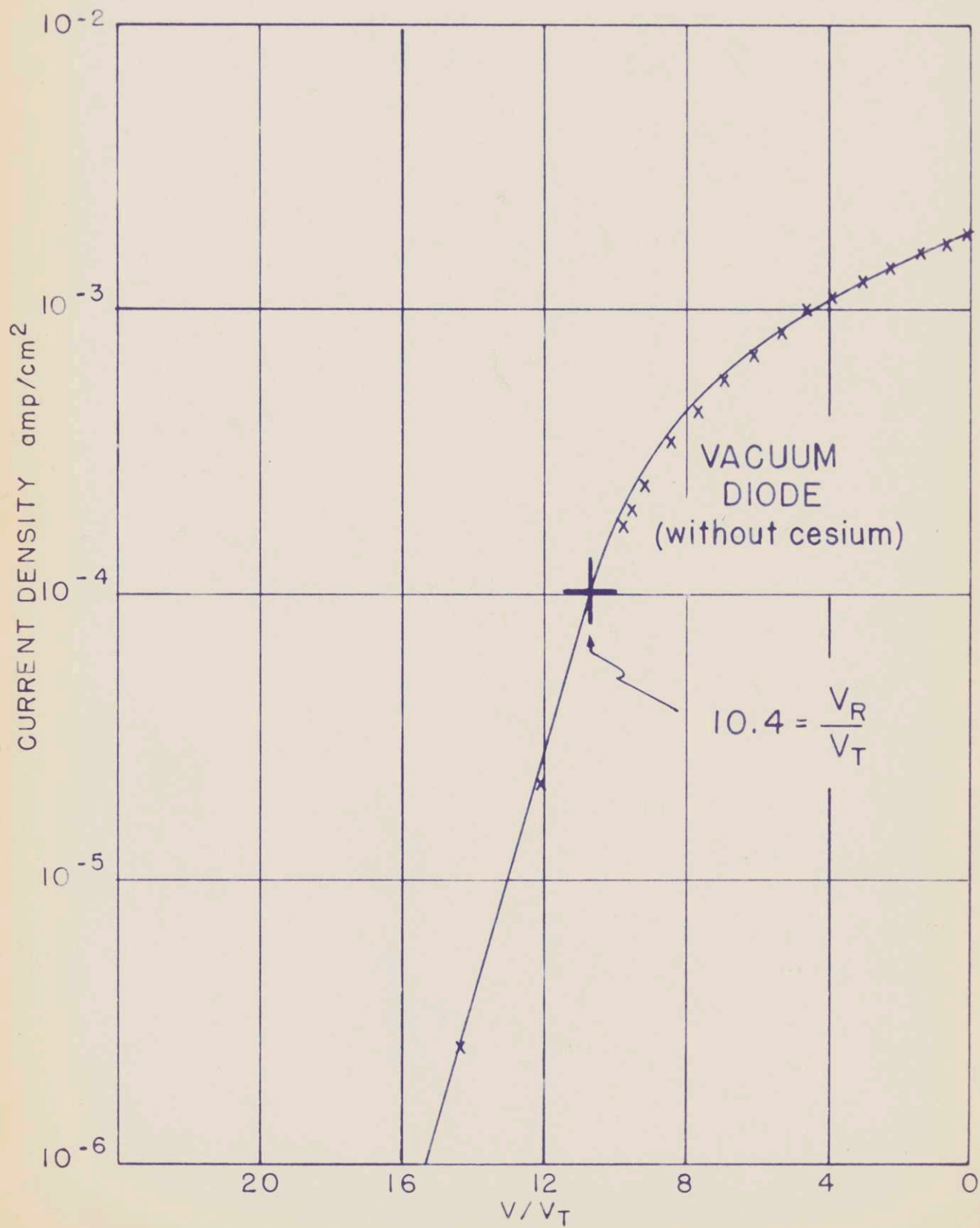

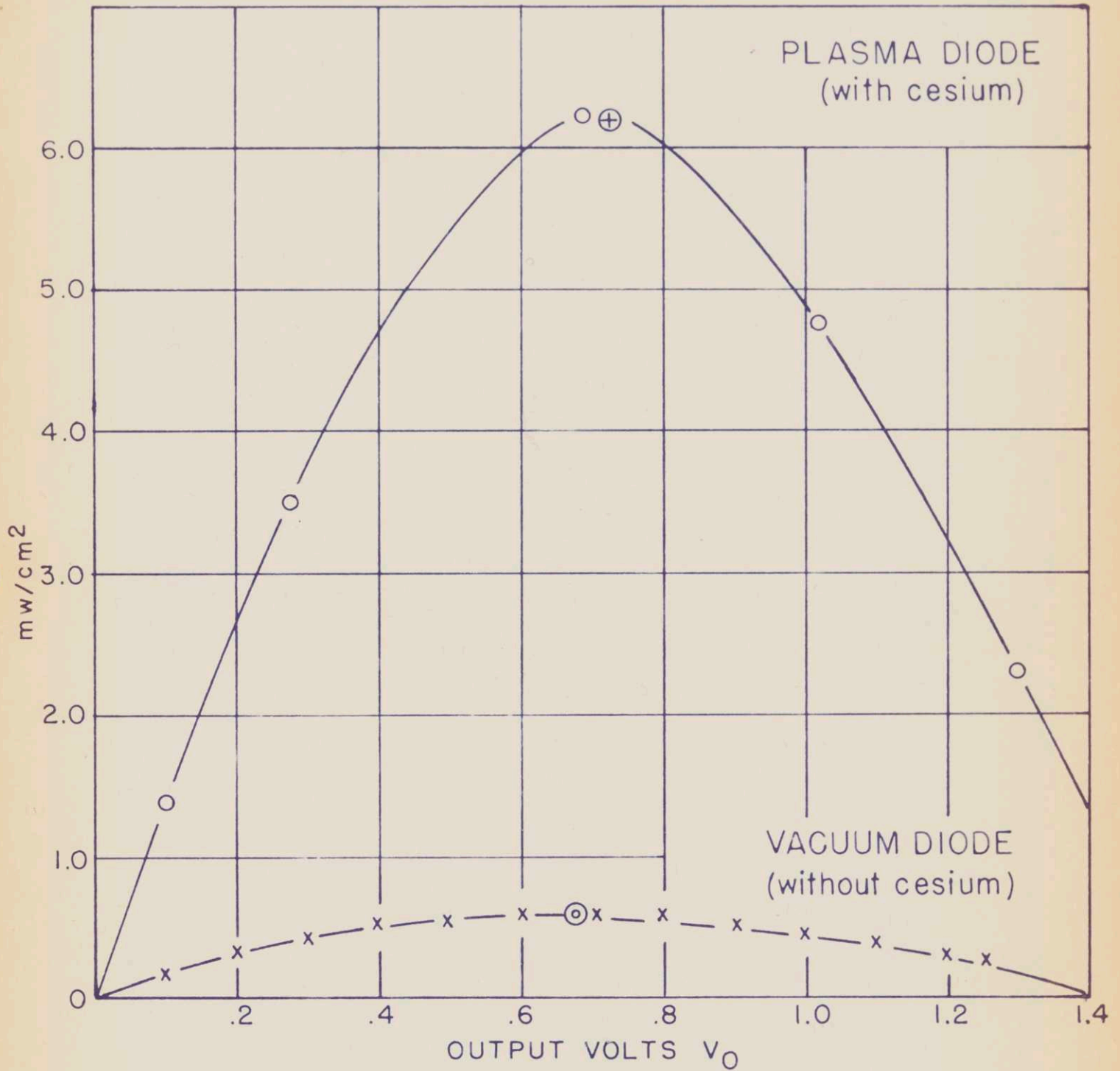
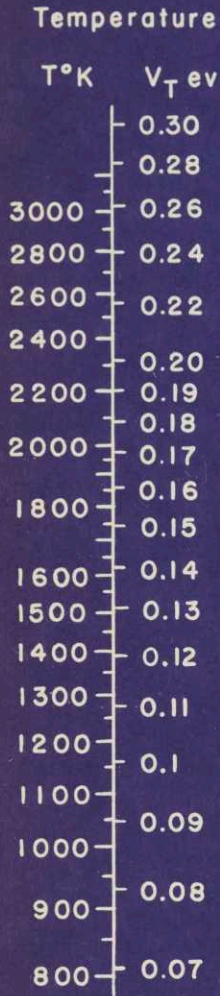

Fig. 10

Observed and calculated power density; x vacuum diode, \circ plasma diode; \odot , \oplus theory. Data from Robinson of TEE.

Current density - Temperature - Spacing relation
in ideal high vacuum diode for onset of space-
charge limitation (zero field at surface of
collector).



$$I_m = 7.729 \times 10^{-12} \frac{T^{3/2}}{w^2} = 9.664 \times 10^{-6} \frac{V_T^{3/2}}{w^2} \text{ amp/cm}^2$$

(for w in cm)

Section 43 of "Thermionic Emission", W. B. Nottingham,
Hand. der Physik, XXI (1956).

Chart gives distance to space-charge minimum as a
function of current density for diode spacing greater
than w.

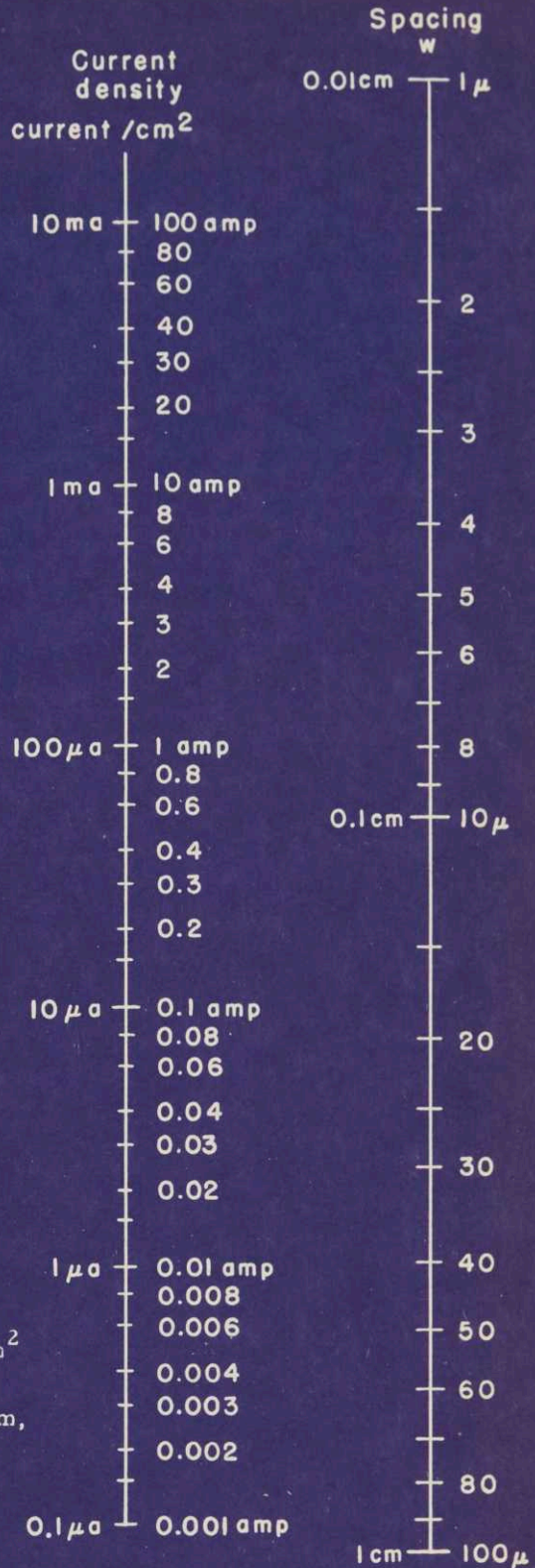

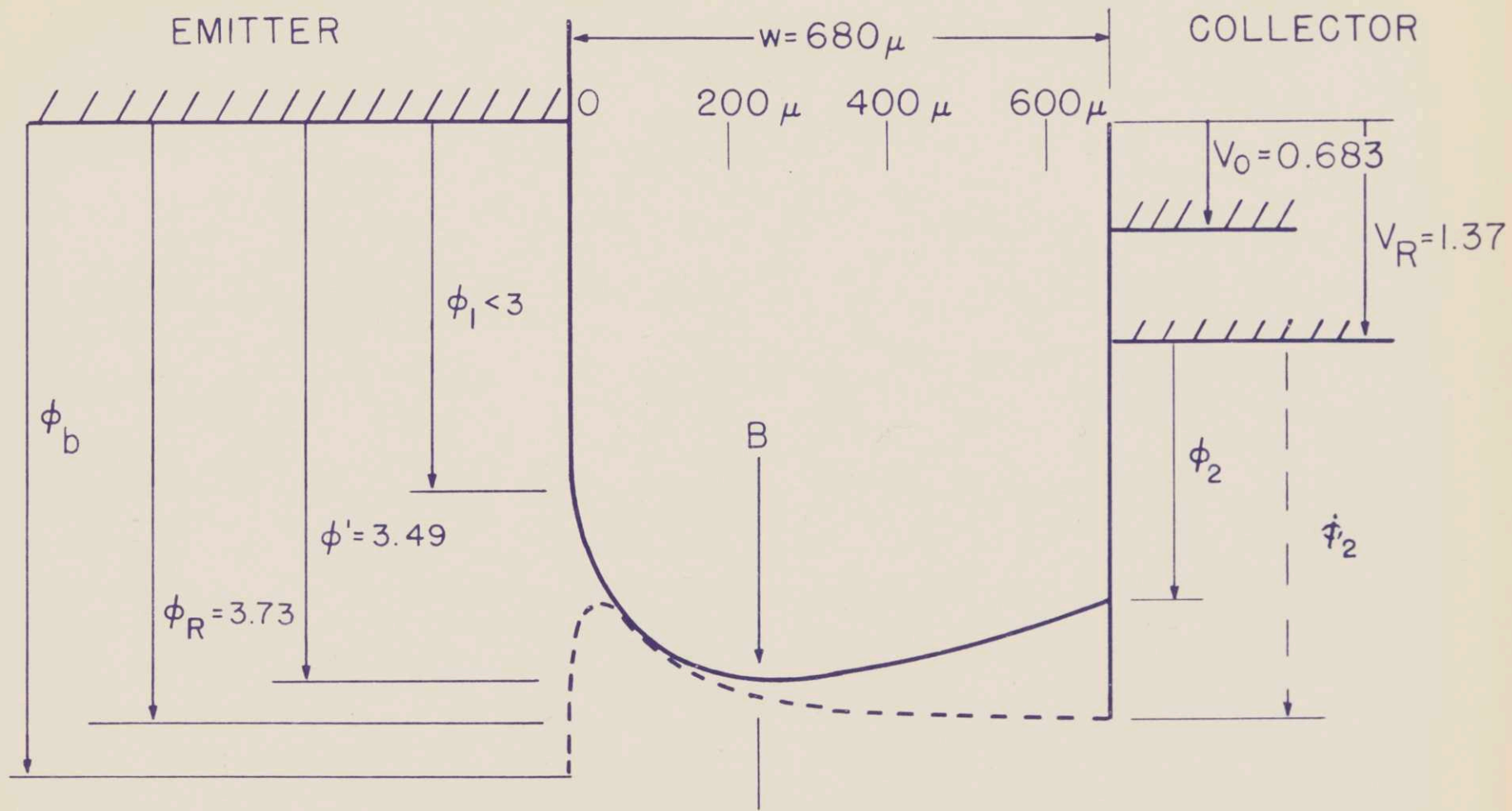

Fig. 12

Motive curve in experimental high-vacuum diode.

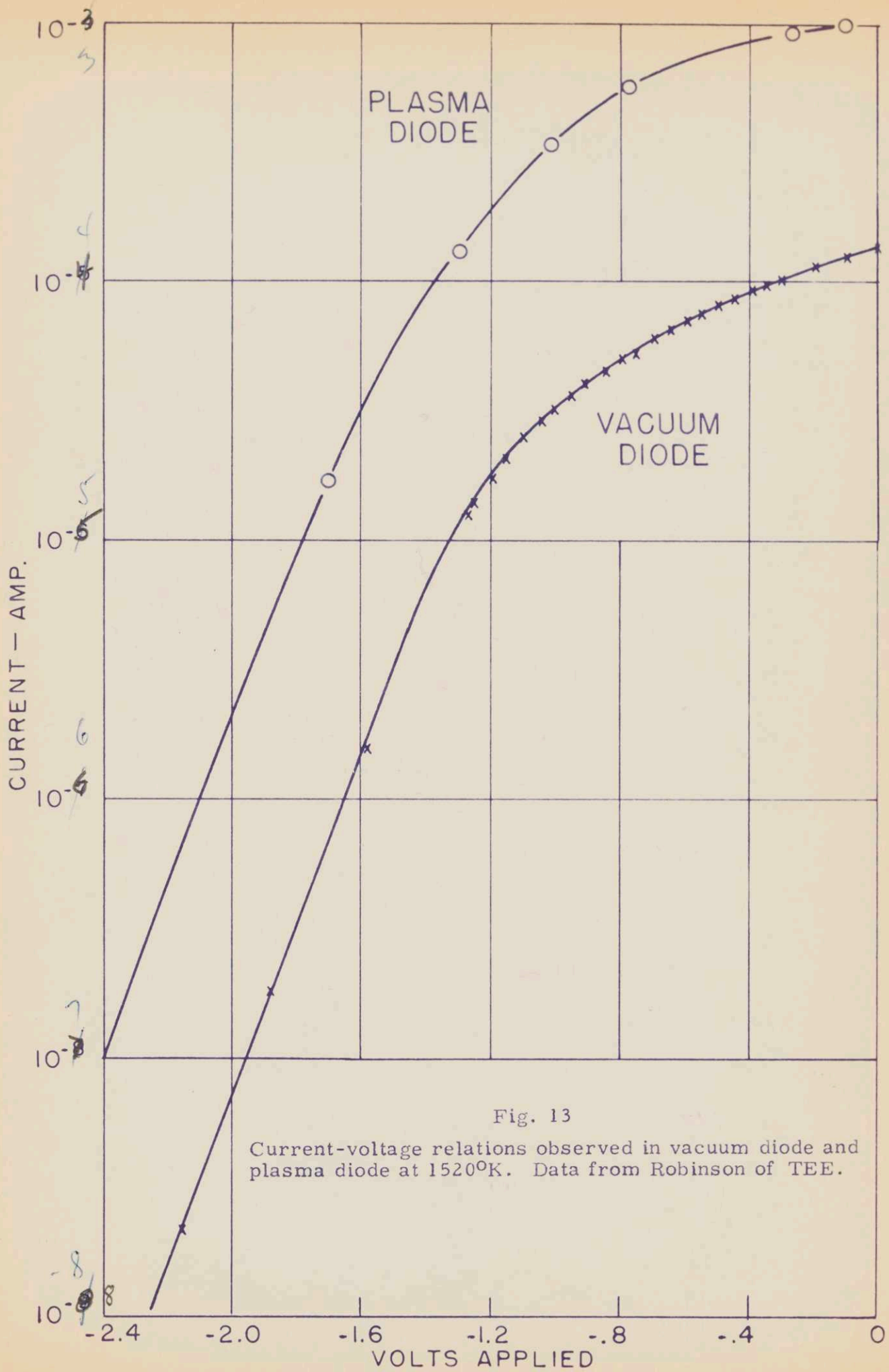
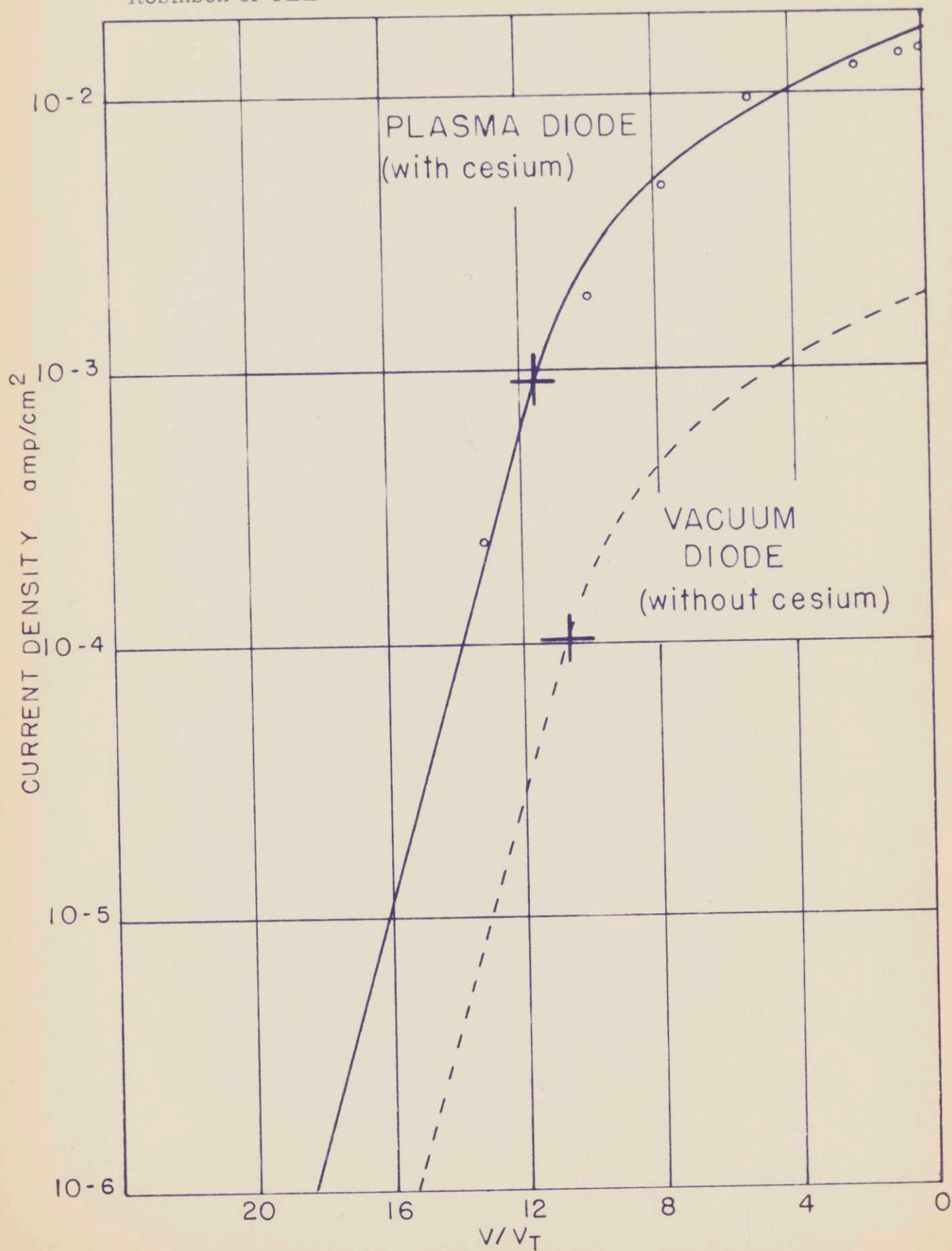

Fig. 13

Current-voltage relations observed in vacuum diode and plasma diode at 1520°K. Data from Robinson of TEE.

Fig. 14

Experimental results and comparison with space-charge theory for plasma diode. (Vacuum diode for comparison). Data from Robinson of TEE.



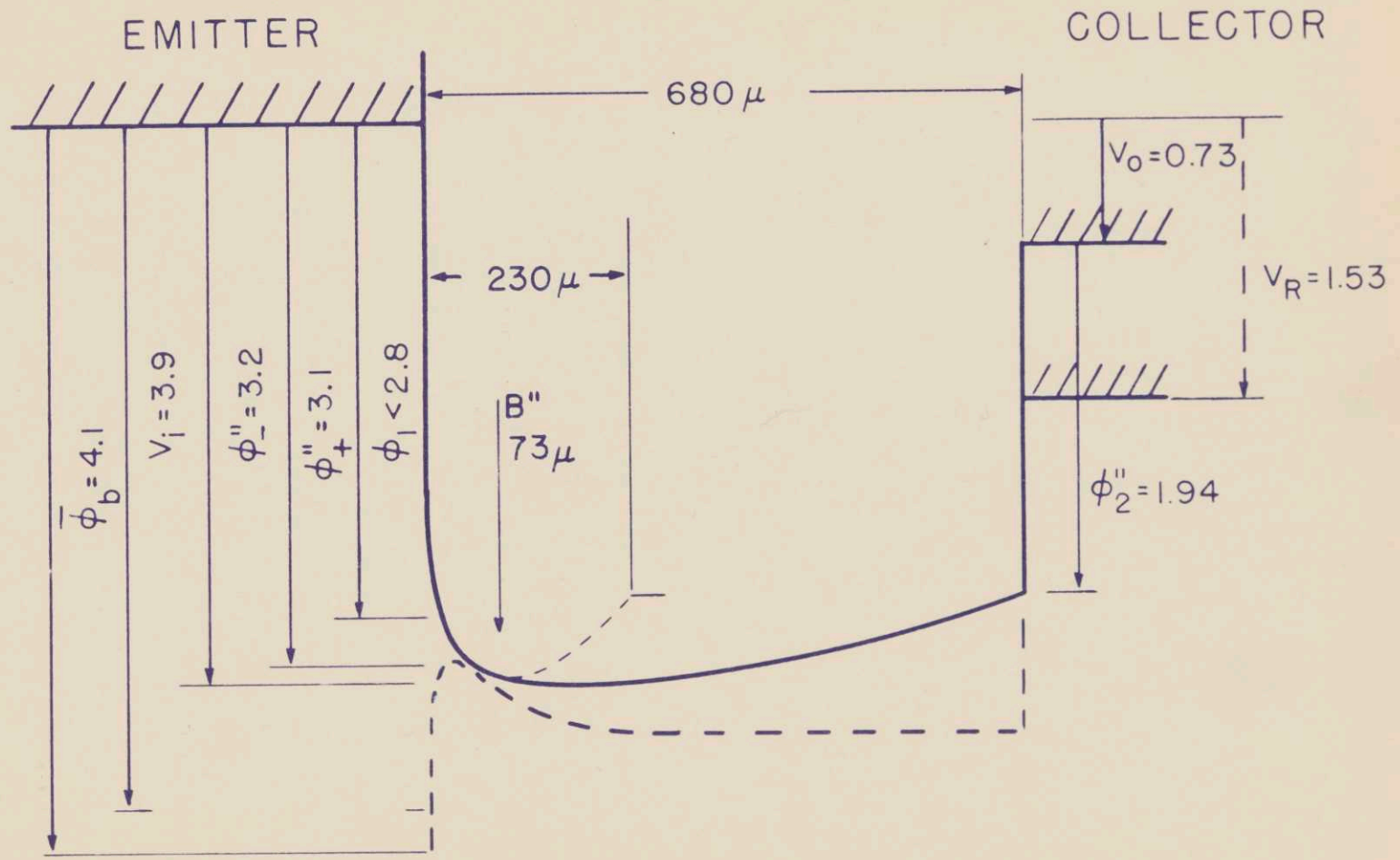

Fig. 16

Motive function for plasma diode.